

YAMAHA

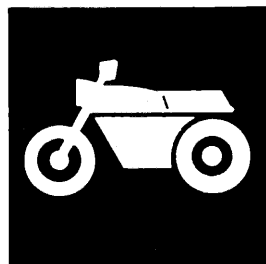

**PARTS
CATALOGUE**

YZ400FK (5BE1) U.S.A., CANADA, OCEANIA

YZ400F'98 (5BE2) EUROPE

YZ400F'98 (5BE3) JAPAN

YAMAHA
GENUINE
Parts & Accessories

185BE-100E2

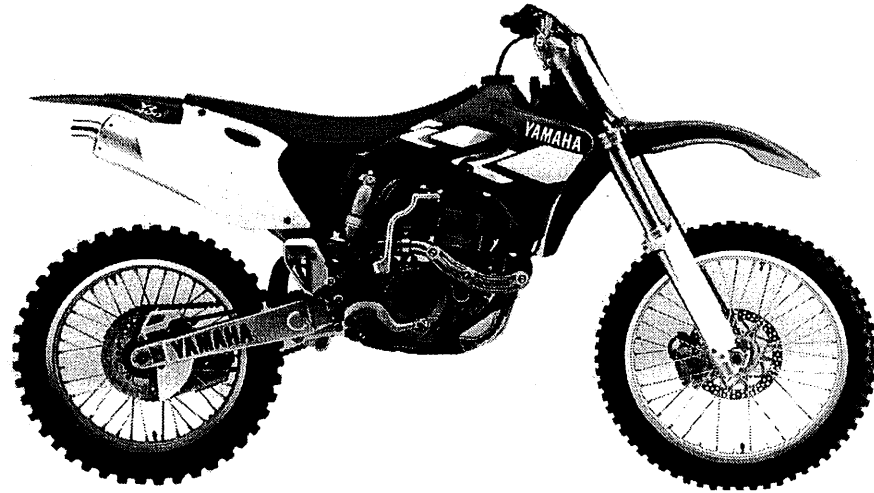

A3

FOREWORD

This Parts Catalogue is related to the parts for the model(s) in the below frame. When you are ordering replacement parts, please refer to this Parts Catalogue and quote both part numbers and part names correctly.

YZ400FK/YZ400F'98(5BE1/5BE2/5BE3)

1. Modifications or additions which have been made after issue of the Parts Catalogue will be announced in the Yamaha Parts News. It is advisable that you make necessary corrections to the Parts Catalogue according to the Yamaha Parts News.

2. Abbreviations
The Following abbreviations are used in this Parts Catalogue.

"UR" Use specified parts number.
 "UN" Use as many as needed.
 "AP" Alternate Parts
 "LM" Local Made (Parts need to be ordered locally)
 "F#" Frame No. (Applicable machine No.)

3. Parts, which are to be supplied in an assembly, are listed with a dot(.) in front of the part name as shown below.

EXAMPLE

CARBURETOR ASSY
 .JET, PILOT
 .NOZZLE, MAIN

4. Number of component for assembly
The numeral appearing to the right of each component part indicates the quantity of parts for each assembly unit.

EXAMPLE

PART NO.	DESCRIPTION	Q'TY	REMARKS
2F5-83310-60	FRONT FLASHER LIGHT ASSY	2	
115-83311-60	.BULB (6V-18W)	1	
1M1-83309-60	.REFLECTOR	1	

5. Applicable colors of graphics are represented in the "REMARKS" as shown below.

PART NO.	DESCRIPTION	Q'TY	REMARKS
2N4-24110-00-X5	.FUEL TANK COMP.	2	MXR
3J1-24240-10	.GRAPHIC, FUEL TANK	1	for MXR

6. Applicable Serial No.

① Engine Serial No.

② Frame Serial No.

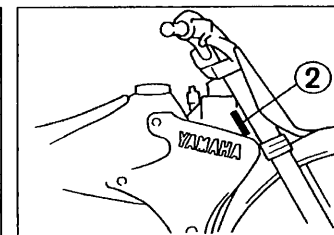
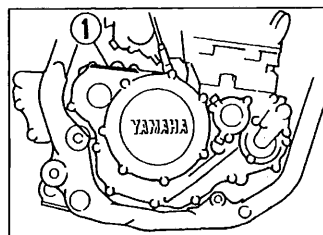

7. Note that the illustrations for reference in finding parts numbers, not to be used for assembling. When assembling, please use the applicable service manual.

8. The asterisk (*) before a reference number indicates modification items after the first edition.

MODEL LABEL

(1) A label called "Model Label" is affixed in the location as indicated in (3) below.
When using this parts catalogue, please be sure to cross-refer the "model code - production code No." in the catalogue to the "model code - production code No." indicated on the Model Label affixed onto the product concerned.

(2) "Model Label" Indication

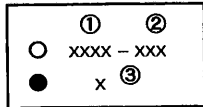

① Model Type Code
② Production Code No.
③ Colouring Type

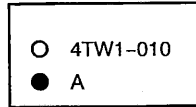

(3) Model Label Affixing Location

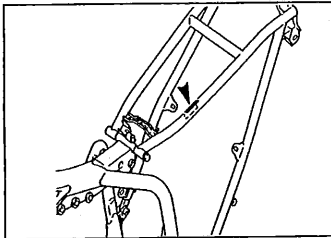

(4) Model Code - Production Code Number of Model Listed in This Parts Catalog

Model Code	Production Code No.	Country (destination)	Model Code	Production Code No.	Country (destination)
5BE1	020	CANADA	5BE2	120	SWEDEN
	030	U.S.A.	5BE3	010	JAPAN
	040	S.AFRICA			
	050	AUSTRALIA			
5BE2	060	NEWZEALAND			
	010	FRANCE			
	030	BELGIUM			
	040	GERMANY			
	050	SPAIN			
	060	FINLAND			
	060	IRELAND			
	070	ENGLAND			
	080	GREECE			
	090	ITALY			
	110	PORTUGAL			

(5) Colouring Information

Model Code	Colouring type code	Colour code	Colour Name	Abbreviation
5BE1	A	0583	DEEP PURPLISH BLUE SOLID E	DPBSE
5BE2/5BE3	B	0206	PURPLISH WHITE SOLID 1	PWS1

CONTENTS

ENGINE

CYLINDER	B2
CRANKSHAFT. PISTON	B4
VALVE	B5
CAMSHAFT. CHAIN	B7
WATER PUMP	B8
RADIATOR. HOSE	B9
OIL PUMP	B10
OIL CLEANER	B12
INTAKE	B13
CARBURETOR	B15
EXHAUST	C6
CRANKCASE	C7
CRANKCASE COVER 1	C8
STARTER	C9
CLUTCH	C10
TRANSMISSION	C11
SHIFT CAM. FORK	C13
SHIFT SHAFT	C14

CHASSIS

FRAME	C15
FENDER	D3
SIDE COVER	D4
REAR ARM	D5
REAR SUSPENSION	D7
STEERING	D8
FRONT FORK	D9
FUEL TANK	D11
SEAT	D13
FRONT WHEEL	D14
FRONT BRAKE CALIPER	D15
REAR WHEEL	E2

REAR BRAKE CALIPER	E4
STEERING HANDLE. CABLE	E5
FRONT MASTER CYLINDER	E6
STAND. FOOTREST	E7
REAR MASTER CYLINDER	E8
GENERATOR	E9
HANDLE SWITCH. LEVER	E10
ELECTRICAL 1	E11
ALTERNATE (CHASSIS)	E12

INDEX

NUMERICAL INDEX	M1
-----------------------	----

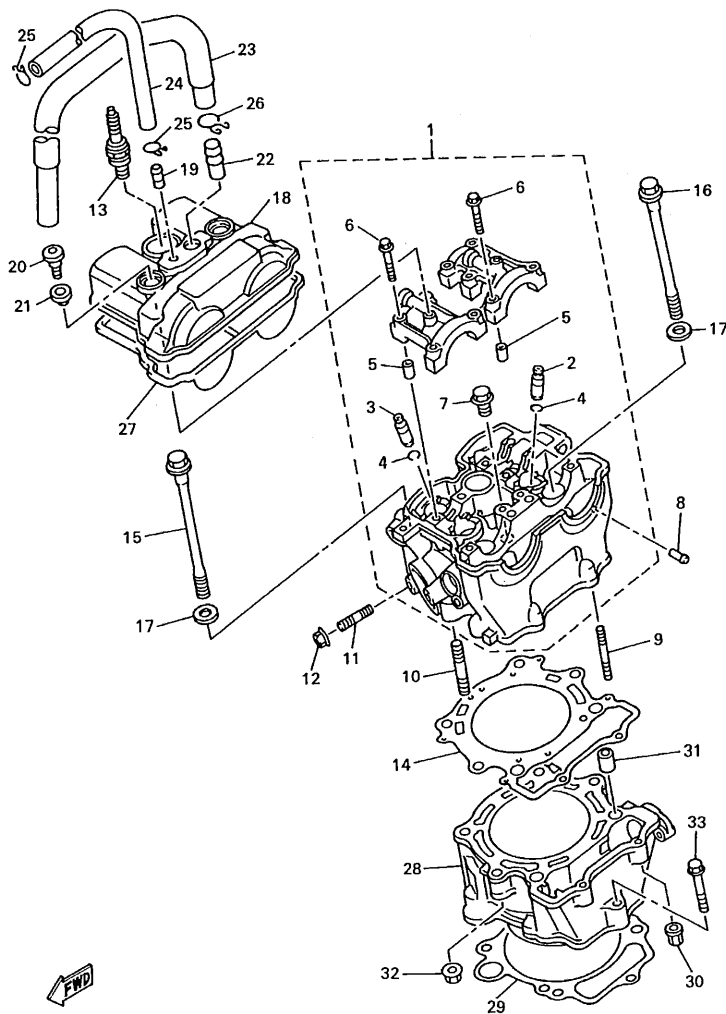

5BE100-8010

FIG. 1 CYLINDER

REF. NO.	PART NO.	DESCRIPTION	USA	CAN	OC	EUR	JPN	REMARKS
1	5BE-11102-00	CYLINDER HEAD ASSY	1	1	1	1	1	
2	5BE-11133-10	.GUIDE, INTAKE VALVE	3	3	3	3	3	
3	5BE-11134-10	.GUIDE, EXHAUST VALVE	2	2	2	2	2	
4	93440-10153	.CIRCLIP	5	5	5	5	5	
5	91808-16023	.PIN, DOWEL	4	4	4	4	4	
6	90105-06153	.BOLT, WASHER BASED	10	10	10	10	10	
7	90340-12112	.PLUG, STRAIGHT SCREW	1	1	1	1	1	
8	5BE-13582-00	PIPE	1	1	1	1	1	
9	95617-06635	BOLT, STUD	2	2	2	2	2	
10	95617-08635	BOLT, STUD	2	2	2	2	2	
11	95617-08620	BOLT, STUD	1	1	1	1	1	
12	95707-08500	NUT, FLANGE	1	1	1	1	1	
13	94701-00330	PLUG, SPARK (NGK-R CR8E)	1	1	1	1	1	UR
	94703-00330	PLUG, SPARK (NGK-R CR8E)					1	UR
	94701-00329	PLUG, SPARK (U24ESR-N)	1	1	1	1	1	UR
	94703-00329	PLUG, SPARK (U24ESR-N)					1	UR
	94701-00318	PLUG, SPARK (NGK R CR9E)	1	1	1	1	1	UR
	94703-00318	PLUG, SPARK (NGK R CR9E)					1	UR
	94701-00319	PLUG, SPARK (ND U27ESR-N)	1	1	1	1	1	UR
	94703-00319	PLUG, SPARK (ND U27ESR-N)					1	UR
14	5BE-11181-00	GASKET, CYLINDER HEAD 1	1	1	1	1	1	
15	90105-104A7	BOLT, WASHER BASED	2	2	2	2	2	
16	90105-106A3	BOLT, WASHER BASED	2	2	2	2	2	
17	90201-101A4	WASHER, PLATE	4	4	4	4	4	
18	5BE-11191-00	COVER, CYLINDER HEAD 1	1	1	1	1	1	
19	5BE-11167-00	PIPE, BREATHER 2	1	1	1	1	1	
20	90109-066F0	BOLT	2	2	2	2	2	

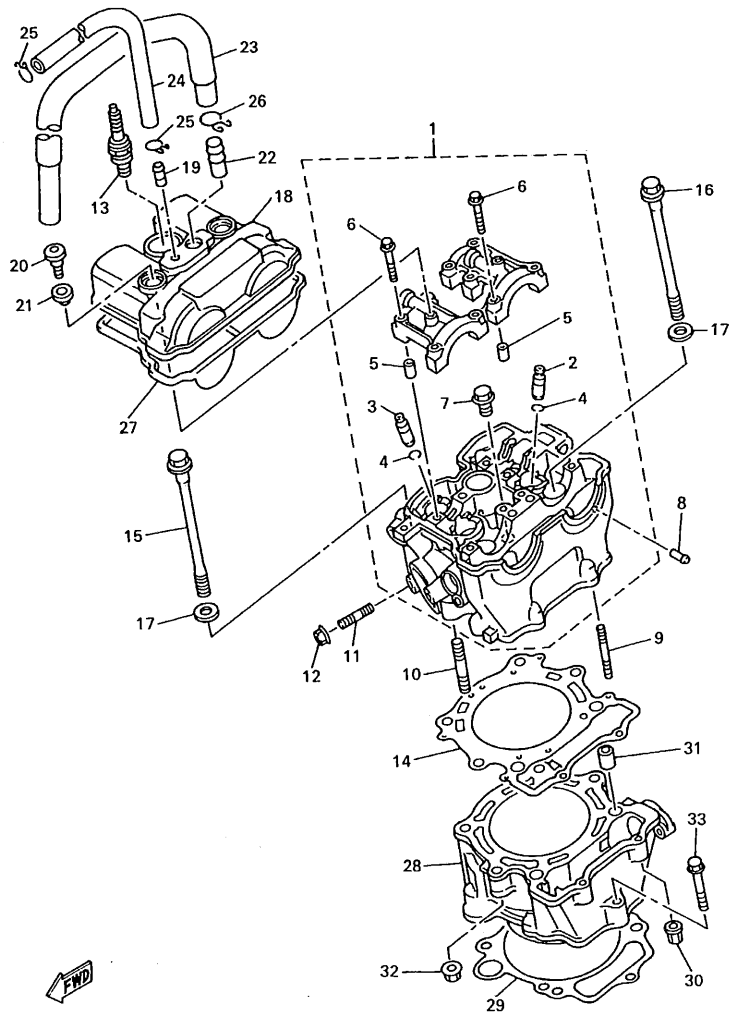

5BE100-8010

FIG. 1 CYLINDER

REF. NO.	PART NO.	DESCRIPTION	USA	CAN	OCE	EUR	JPN	REMARKS
21	4KG-1111G-00	RUBBER, MOUNT 1	2	2	2	2	2	
22	371-11167-01	PIPE, BREATHER 2	1	1	1	1	1	
23	5BE-11166-00	PIPE, BREATHER 1	1	1	1	1	1	
24	90445-112K0	HOSE	1	1	1	1	1	
25	90467-11106	CLIP	2	2	2	2	2	
26	90467-14015	CLIP	1	1	1	1	1	
27	5BE-11193-00	GASKET, HEAD COVER 1	1	1	1	1	1	
28	5BE-11311-00	CYLINDER 1	1	1	1	1	1	
29	5BE-11351-00	GASKET, CYLINDER	1	1	1	1	1	
30	90179-06500	NUT	2	2	2	2	2	
31	93612-16254	PIN, DOWEL	2	2	2	2	2	
32	90179-08270	NUT	2	2	2	2	2	
33	95027-06040	BOLT, FLANGE	1	1	1	1	1	

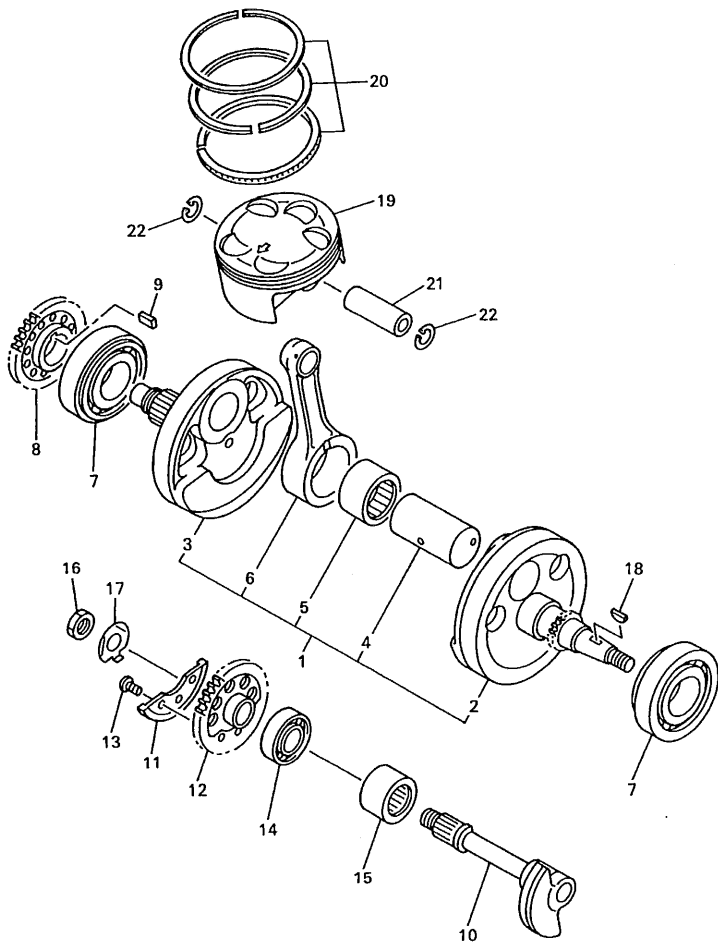

5BE100-8020

FIG. 2 CRANKSHAFT. PISTON

REF. NO.	PART NO.	DESCRIPTION	USA	CAN	OC	EUR	JPN	REMARKS
1	5BE-11400-00	CRANKSHAFT ASSY	1	1	1	1	1	
2	5BE-11412-00	.CRANK 1	1	1	1	1	1	
3	5BE-11422-00	.CRANK 2	1	1	1	1	1	
4	5BE-11681-00	.PIN, CRANK 1	1	1	1	1	1	
5	93310-6340F	.BEARING	1	1	1	1	1	
6	5BE-11651-00	.ROD, CONNECTING	1	1	1	1	1	
7	93306-30633	BEARING	2	2	2	2	2	
8	5BE-11536-00	GEAR, DRIVE	1	1	1	1	1	
9	90282-05034	KEY, STRAIGHT	1	1	1	1	1	
10	5BE-11455-00	SHAFT 1	1	1	1	1	1	
11	5BE-11454-00	WEIGHT 1	1	1	1	1	1	
12	5BE-11531-00	GEAR, BALANCE WT	1	1	1	1	1	
13	90149-06250	SCREW	3	3	3	3	3	
14	93306-20335	BEARING	1	1	1	1	1	
15	93311-62574	BEARING	1	1	1	1	1	
16	90170-14171	NUT	1	1	1	1	1	
17	90215-14204	WASHER, LOCK	1	1	1	1	1	
18	90280-03045	KEY, WOODRUFF	1	1	1	1	1	
19	5BE-11631-01-A0	PISTON (STD)	1	1	1	1	1	UR
	5BE-11631-01-B0	PISTON (STD)	1	1	1	1	1	UR
20	5BE-11603-00	PISTON RING SET (STD)	1	1	1	1	1	
21	5BE-11633-00	PIN, PISTON	1	1	1	1	1	
22	93420-18082	CIRCLIP	2	2	2	2	2	

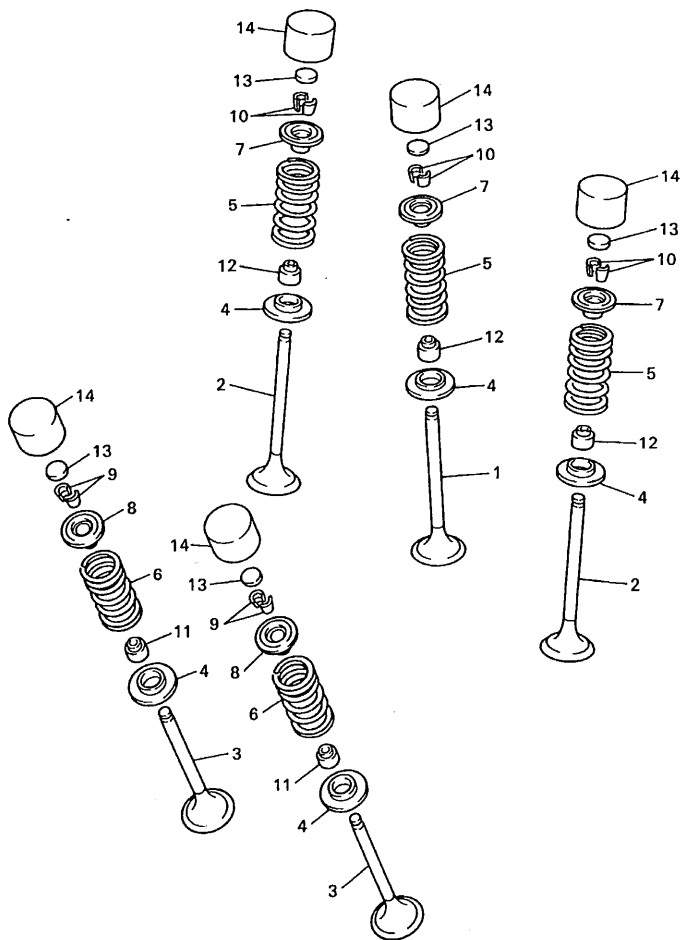

5BE100-8030

FIG. 3 VALVE

REF. NO.	PART NO.	DESCRIPTION	USA	CAN	OE	EUR	JPN	REMARKS
1	5BE-12111-00	VALVE, INTAKE	1	1	1	1	1	
2	5BE-12112-00	VALVE, INTAKE 2	2	2	2	2	2	
3	5BE-12121-00	VALVE, EXHAUST	2	2	2	2	2	
4	3GM-12126-00	SEAT, VALVE SPRING 2	5	5	5	5	5	
5	5BE-12113-00	SPRING, VALVE INNER	3	3	3	3	3	
6	5BE-12114-00	SPRING, VALVE OUTER	2	2	2	2	2	
7	5BE-12117-00	RETAINER, VALVE SPRING	3	3	3	3	3	
8	4GY-12117-00	RETAINER, VALVE SPRING	2	2	2	2	2	
9	1AA-12118-00	COTTER, VALVE	4	4	4	4	4	
10	1WG-12118-00	COTTER, VALVE	6	6	6	6	6	
11	33M-12119-00	SEAL, VALVE STEM	2	2	2	2	2	
12	4SV-12119-00	SEAL, VALVE STEM	3	3	3	3	3	
13	3LD-12168-00	PAD, ADJUSTING (1.20)	5	5	5	5	5	UR
	3LD-12168-20	PAD, ADJUSTING (1.25)	5	5	5	5	5	UR
	3LD-12168-40	PAD, ADJUSTING (1.30)	5	5	5	5	5	UR
	3LD-12168-60	PAD, ADJUSTING (1.35)	5	5	5	5	5	UR
	3LD-12168-80	PAD, ADJUSTING (1.40)	5	5	5	5	5	UR
	3LD-12168-A0	PAD, ADJUSTING (1.45)	5	5	5	5	5	UR
	3LD-12168-F0	PAD, ADJUSTING (1.50)	5	5	5	5	5	UR
	3LD-12168-H1	PAD, ADJUSTING (1.55)	5	5	5	5	5	UR
	3LD-12168-K1	PAD, ADJUSTING (1.60)	5	5	5	5	5	UR
	3LD-12168-M1	PAD, ADJUSTING (1.65)	5	5	5	5	5	UR
	3LD-12168-R1	PAD, ADJUSTING (1.70)	5	5	5	5	5	UR
	3LD-12168-U1	PAD, ADJUSTING (1.75)	5	5	5	5	5	UR
	3LD-12168-W1	PAD, ADJUSTING (1.80)	5	5	5	5	5	UR
	3LD-12168-Y1	PAD, ADJUSTING (1.85)	5	5	5	5	5	UR
	3LD-12169-11	PAD, ADJUSTING (1.90)	5	5	5	5	5	UR

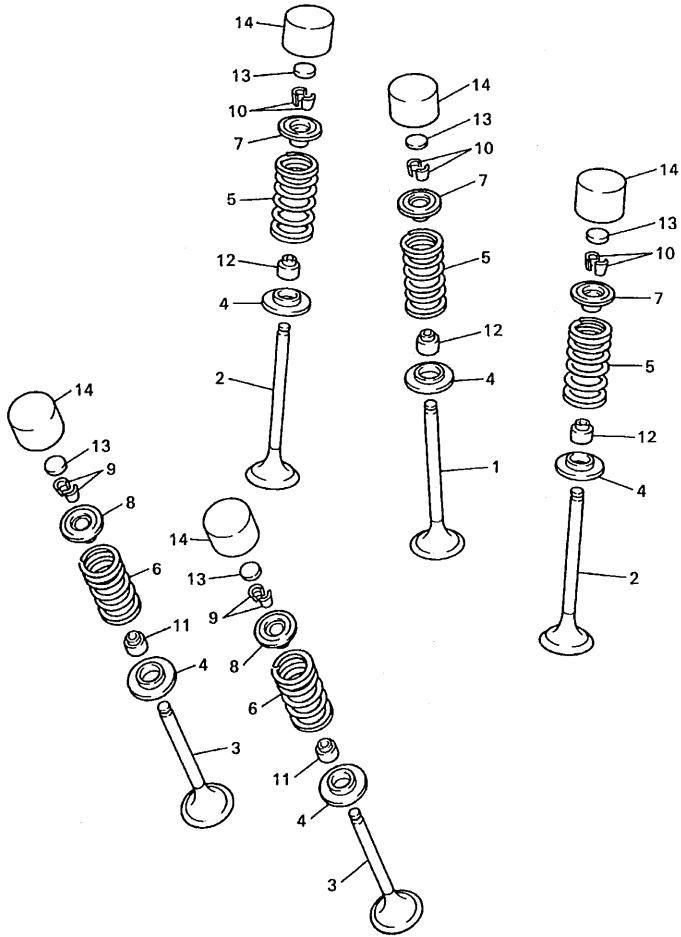

5BE100-8030

FIG. 3 VALVE

REF. NO.	PART NO.	DESCRIPTION	USA	CAN	OCE	EUR	JPN	REMARKS
13	3LD-12169-31	PAD, ADJUSTING (1.95)	5	5	5	5	5	UR
	3LD-12169-50	PAD, ADJUSTING (2.00)	5	5	5	5	5	UR
	3LD-12169-70	PAD, ADJUSTING (2.05)	5	5	5	5	5	UR
	3LD-12169-90	PAD, ADJUSTING (2.10)	5	5	5	5	5	UR
	3LD-12169-E0	PAD, ADJUSTING (2.15)	5	5	5	5	5	UR
	3LD-12169-G0	PAD, ADJUSTING (2.20)	5	5	5	5	5	UR
	3LD-12169-J0	PAD, ADJUSTING (2.25)	5	5	5	5	5	UR
	3LD-12169-L0	PAD, ADJUSTING (2.30)	5	5	5	5	5	UR
	3LD-12169-N0	PAD, ADJUSTING (2.35)	5	5	5	5	5	UR
	3LD-12169-T0	PAD, ADJUSTING (2.40)	5	5	5	5	5	UR
*14	3FV-12153-00	LIFTER, VALVE	5	5	5	5	5	UR BLACK
	3FV-12153-10	LIFTER, VALVE	5	5	5	5	5	UR YELLOW
	3FV-12153-20	LIFTER, VALVE	5	5	5	5	5	UR BLUE

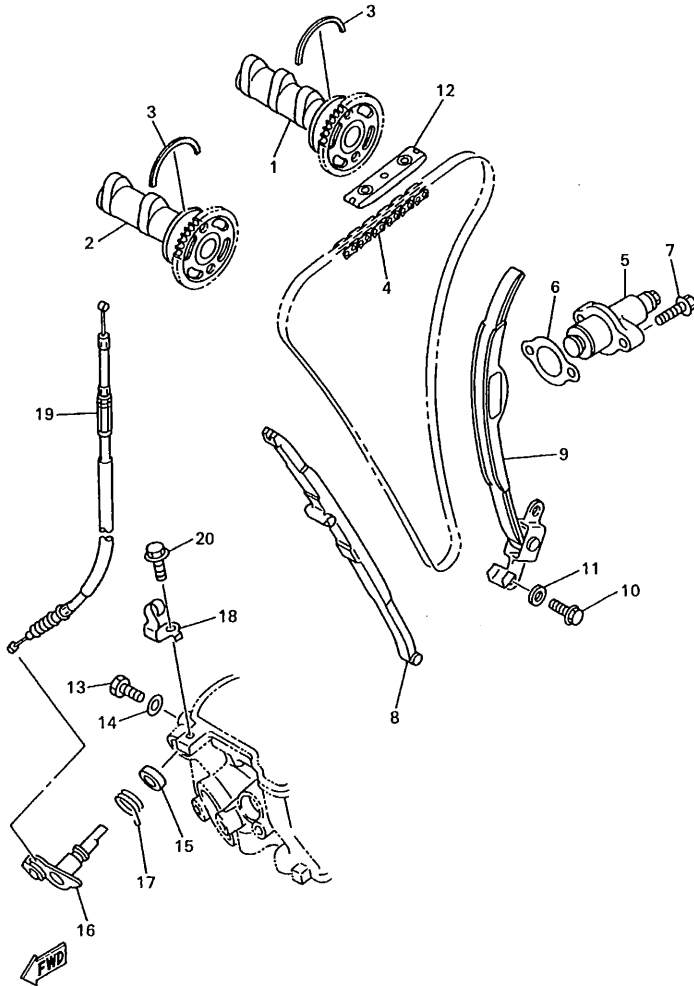

5BE100-8040

FIG. 4 CAMSHAFT. CHAIN

REF. NO.	PART NO.	DESCRIPTION	USA	CAN	OC	EUR	JPN	REMARKS
1	5BE-12170-00	CAMSHAFT ASSY 1	1	1	1	1	1	
2	5BE-12180-00	CAMSHAFT ASSY 2	1	1	1	1	1	
3	93440-41178	CIRCLIP	2	2	2	2	2	
4	94591-50120	CHAIN	1	1	1	1	1	
5	5BE-12210-00	TENSIONER ASSY, CAM CHAIN	1	1	1	1	1	
6	4FM-12213-00	GASKET, TENSIONER CASE	1	1	1	1	1	
7	95027-06025	BOLT, FLANGE	2	2	2	2	2	
8	5BE-12251-00	DAMPER, CHAIN 1	1	1	1	1	1	
9	5BE-12252-00	DAMPER, CHAIN 2	1	1	1	1	1	
10	97027-06016	BOLT	2	2	2	2	2	
11	92907-06600	WASHER, PLATE	2	2	2	2	2	
12	5BE-12241-00	GUIDE, STOPPER 2	1	1	1	1	1	
13	90109-06418	BOLT	1	1	1	1	1	
14	90430-06014	GASKET	1	1	1	1	1	
15	93102-12224	OIL SEAL	1	1	1	1	1	
16	5BE-12280-00	DECOMPRESSION ASSY	1	1	1	1	1	
17	90508-162B2	SPRING, TORSION	1	1	1	1	1	
18	5BE-12283-00	BRACKET, DECOMPRESSION	1	1	1	1	1	
19	5BE-12292-00	CABLE, DECOMPRESSION	1	1	1	1	1	
20	95827-06014	BOLT, FLANGE	1	1	1	1	1	

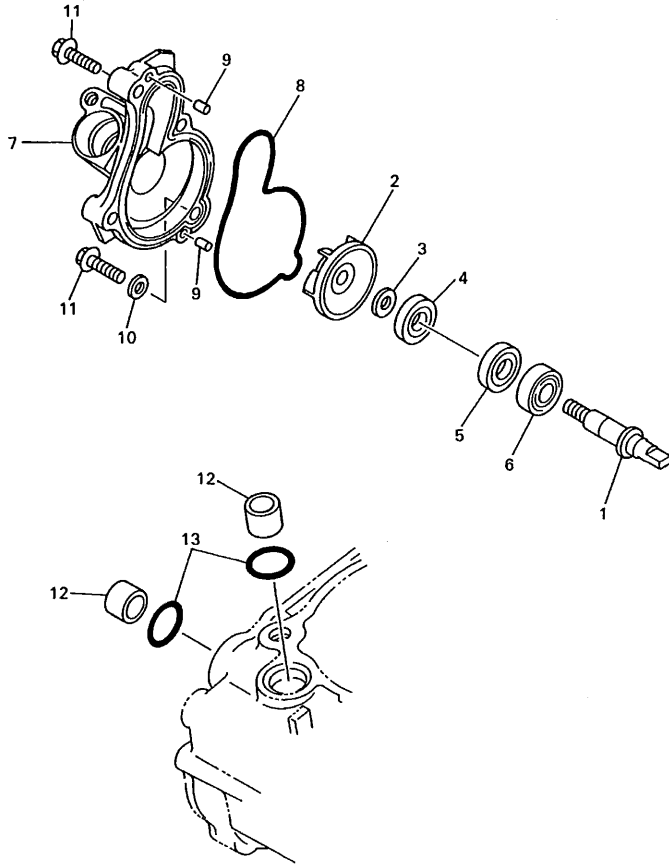
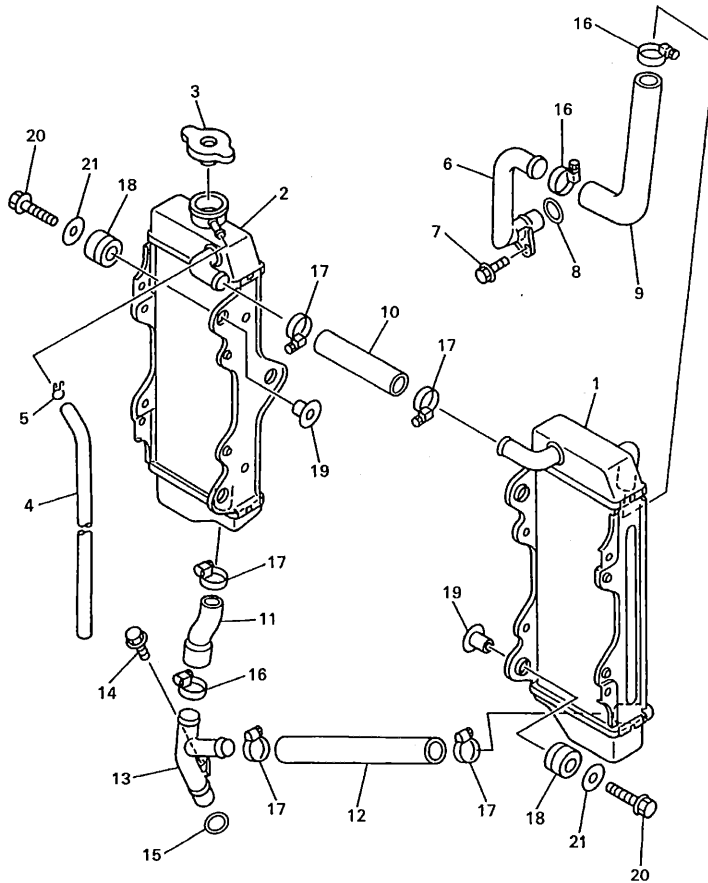

FIG. 5 WATER PUMP

REF. NO.	PART NO.	DESCRIPTION	USA	CAN	OCE	EUR	JPN	REMARKS
1	5BE-12458-00	SHAFT, IMPELLER	1	1	1	1	1	
2	5DJ-12451-00	IMPELLER, WATER PUMP	1	1	1	1	1	
3	90201-08512	WASHER, PLATE	1	1	1	1	1	
4	93109-11073	OIL SEAL	1	1	1	1	1	
5	93102-12106	OIL SEAL (SD 12-22-5 HS)	1	1	1	1	1	
6	93306-00105	BEARING (B6001)	1	1	1	1	1	
7	5BE-12422-00	COVER, HOUSING	1	1	1	1	1	
8	5BE-12439-00	O-RING	1	1	1	1	1	
9	93604-10011	PIN, DOWEL	2	2	2	2	2	
10	90430-06166	GASKET	1	1	1	1	1	
11	95027-06025	BOLT, FLANGE	4	4	4	4	4	
12	5BE-12564-00	PIPE, WATER	2	2	2	2	2	
13	93210-19758	O-RING	2	2	2	2	2	



 5BE100-8050



FWD
5BE100-8060

FIG. 6 RADIATOR. HOSE

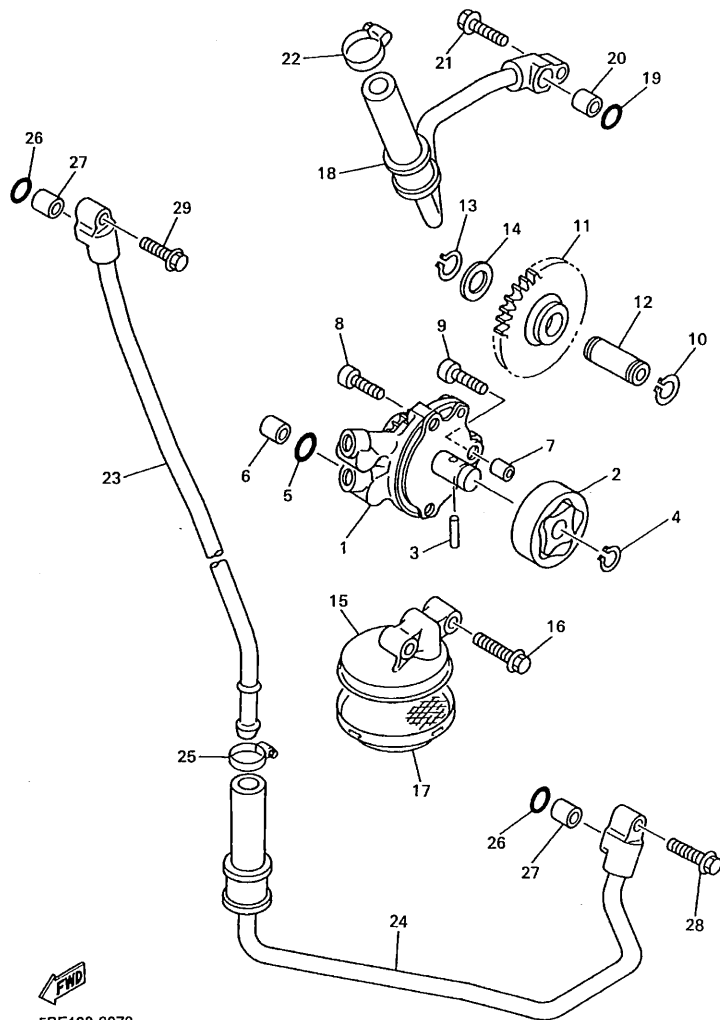
REF. NO.	PART NO.	DESCRIPTION	USA	CAN	OCE	EUR	JPN	REMARKS
1	5BE-1240A-00	RADIATOR ASSY	1	1	1	1	1	
2	5BE-12461-00	RADIATOR ASSY	1	1	1	1	1	
3	22W-12462-00	CAP, RADIATOR	1	1	1	1	1	
4	91A20-05065	TUBE, FLEXIBLE VINYL	1	1	1	1	1	
5	90467-09006	CLIP	1	1	1	1	1	
6	5BE-12481-00	PIPE 1	1	1	1	1	1	
7	95027-06012	BOLT, FLANGE	1	1	1	1	1	
8	93210-18397	O-RING	1	1	1	1	1	
9	5BE-12576-00	HOSE 1	1	1	1	1	1	
10	5BE-12577-00	HOSE 2	1	1	1	1	1	
11	5BE-12578-00	HOSE 3	1	1	1	1	1	
12	5BE-12579-00	HOSE 4	1	1	1	1	1	
13	5BE-12482-00	PIPE 2	1	1	1	1	1	
14	95027-06012	BOLT, FLANGE	1	1	1	1	1	
15	93210-18397	O-RING	1	1	1	1	1	
16	90450-28014	HOSE CLAMP ASSY	3	3	3	3	3	
17	90450-25037	HOSE CLAMP ASSY	5	5	5	5	5	
18	90480-15528	GROMMET	6	6	6	6	6	
19	90387-0614M	COLLAR	6	6	6	6	6	
20	95027-06025	BOLT, FLANGE	6	6	6	6	6	
21	90201-06071	WASHER, PLATE	6	6	6	6	6	



5BE100-8070

FIG. 7 OIL PUMP

REF. NO.	PART NO.	DESCRIPTION	USA	CAN	OCÉ	EUR	JPN	REMARKS
1	5BE-13300-00	OIL PUMP ASSY	1	1	1	1	1	
2	1HX-13310-00	ROTOR ASSY 1	1	1	1	1	1	
3	93603-17070	PIN, DOWEL	1	1	1	1	1	
4	93440-10085	CIRCLIP	1	1	1	1	1	
5	93210-10197	O-RING	1	1	1	1	1	
6	99530-10114	PIN, DOWEL	1	1	1	1	1	
7	99530-08012	PIN, DOWEL	1	1	1	1	1	
8	91317-06025	BOLT	2	2	2	2	2	
9	91314-06030	BOLT	1	1	1	1	1	
10	99001-08600	CIRCLIP	1	1	1	1	1	
11	5BE-13341-00	GEAR, OIL PUMP IDLE	1	1	1	1	1	
12	5BE-13342-00	SHAFT, IDLE GEAR	1	1	1	1	1	
13	99009-12400	CIRCLIP	1	1	1	1	1	
14	90201-12166	WASHER, PLATE	1	1	1	1	1	
15	5BE-13412-00	HOUSING, STRAINER	1	1	1	1	1	
16	95027-06025	BOLT, FLANGE	2	2	2	2	2	
17	5BE-13411-00	STRAINER, OIL	1	1	1	1	1	
18	5BE-13464-00	HOSE, OIL 1	1	1	1	1	1	
19	93210-10197	O-RING	1	1	1	1	1	
20	99530-10114	PIN, DOWEL	1	1	1	1	1	
21	95027-06025	BOLT, FLANGE	1	1	1	1	1	
22	90450-22017	HOSE CLAMP ASSY	1	1	1	1	1	
23	5BE-13416-00	PIPE, OIL 1	1	1	1	1	1	
24	5BE-13465-00	HOSE, OIL 2	1	1	1	1	1	
25	90450-22017	HOSE CLAMP ASSY	1	1	1	1	1	
26	93210-10197	O-RING	2	2	2	2	2	
27	99530-10114	PIN, DOWEL	2	2	2	2	2	

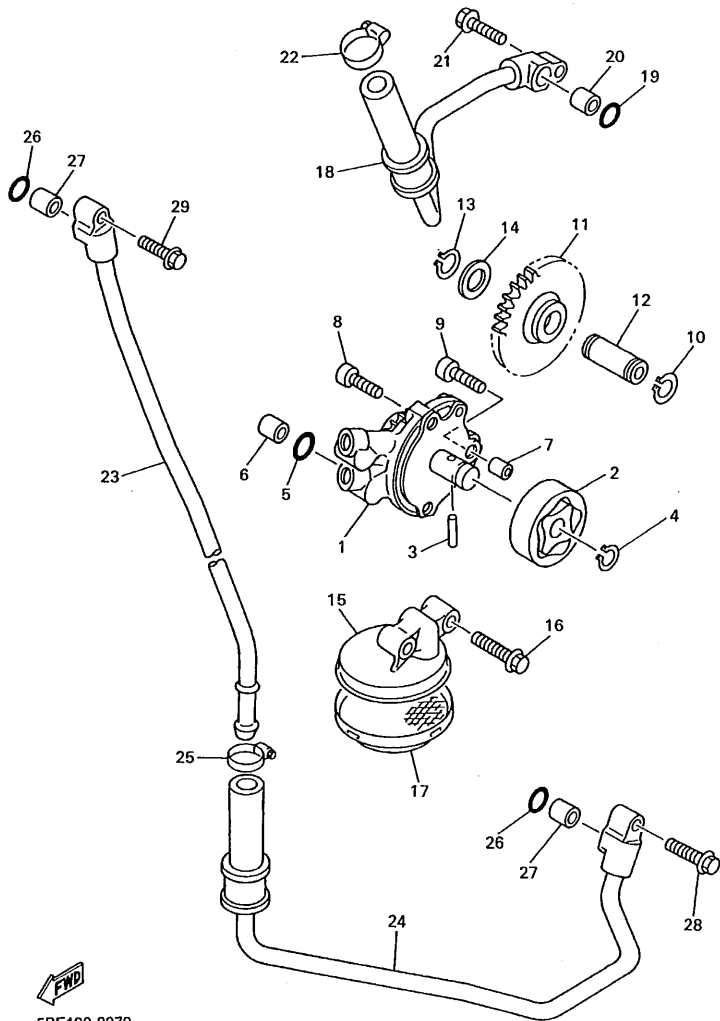

5BE100-8070

FIG. 7 OIL PUMP

REF. NO.	PART NO.	DESCRIPTION	USA	CAN	OCE	EUR	JPN	REMARKS
28	95027-06025	BOLT, FLANGE	1	1	1	1	1	
29	95024-06020	BOLT, FLANGE	1	1	1	1	1	

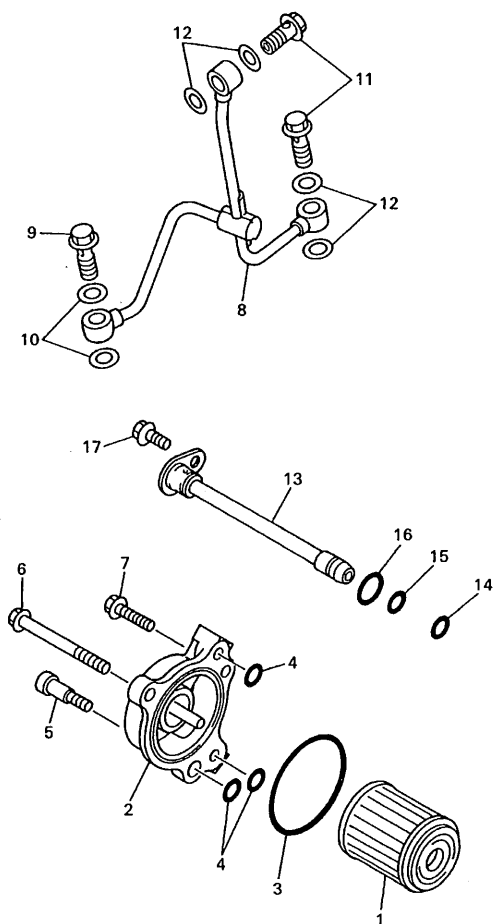

FWD
5BE100-8080

FIG. 8 OIL CLEANER

REF. NO.	PART NO.	DESCRIPTION	USA	CAN	OC	EUR	JPN	REMARKS
1	1UY-13440-02	ELEMENT ASSY, OIL CLEANER	1	1	1	1	1	
2	5BE-13447-00	COVER, OIL ELEMENT	1	1	1	1	1	
3	93210-50553	O-RING	1	1	1	1	1	
4	93210-07135	O-RING	3	3	3	3	3	
5	90109-065G2	BOLT	1	1	1	1	1	
6	95027-06065	BOLT, FLANGE	1	1	1	1	1	
7	95027-06020	BOLT, FLANGE	1	1	1	1	1	
8	5BE-13161-00	PIPE, DELIVERY 1	1	1	1	1	1	
9	90401-10159	BOLT, UNION	1	1	1	1	1	
10	90430-10188	GASKET	2	2	2	2	2	
11	90401-08038	BOLT, UNION	2	2	2	2	2	
12	90430-08119	GASKET	4	4	4	4	4	
13	5BE-13171-00	PIPE, DELIVERY 2	1	1	1	1	1	
14	93210-07003	O-RING	1	1	1	1	1	
15	93210-09008	O-RING	1	1	1	1	1	
16	93210-12759	O-RING	1	1	1	1	1	
17	95027-06012	BOLT, FLANGE	1	1	1	1	1	

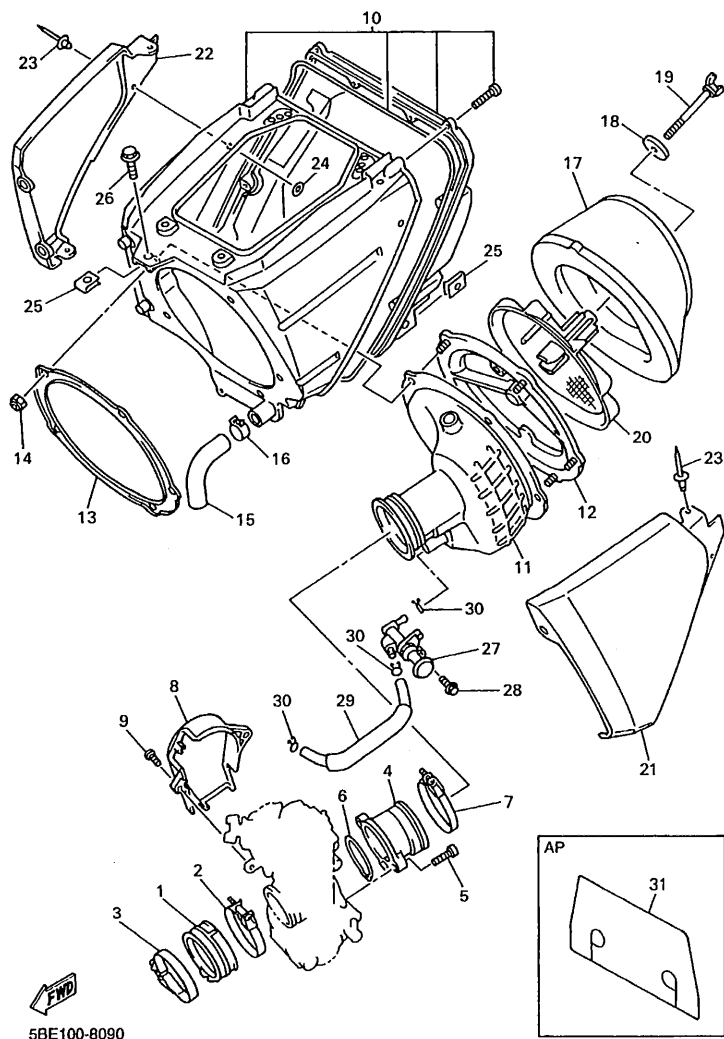

5BE100-8090

FIG. 9 INTAKE

REF. NO.	PART NO.	DESCRIPTION	USA	CAN	OCÉ	EUR	JPN	REMARKS
1	5BE-13597-00	JOINT, CARBURETOR 3	1	1	1	1	1	
2	90450-57092	HOSE CLAMP ASSY	1	1	1	1	1	
3	90450-59091	HOSE CLAMP ASSY	1	1	1	1	1	
4	5BE-1440F-00	JOINT, AIR FILTER 1	1	1	1	1	1	
5	91317-05014	BOLT	2	2	2	2	2	
6	4FN-14561-00	O-RING	1	1	1	1	1	
7	90460-61162	CLAMP, HOSE	1	1	1	1	1	
8	5BE-14293-00	COVER 1	1	1	1	1	1	
9	90111-06017	BOLT	2	2	2	2	2	
10	5BE-14401-00	AIR CLEANER CASE ASSY	1	1	1	1	1	
11	5BE-14453-00	JOINT, AIR CLEANER 1	1	1	1	1	1	
12	3JD-14459-01	HOLDER, GUIDE	1	1	1	1	1	
13	3JD-14477-00	PLATE	1	1	1	1	1	
14	95607-05100	NUT, U	5	5	5	5	5	
15	5BE-1443E-00	PIPE, DRAIN	1	1	1	1	1	
16	90467-17089	CLIP	1	1	1	1	1	
17	4XM-14451-00	ELEMENT, AIR CLEANER	1	1	1	1	1	
18	90209-06096	WASHER	1	1	1	1	1	
19	90122-06035	BOLT, WING	1	1	1	1	1	
20	5BE-14458-00	GUIDE	1	1	1	1	1	
21	5BE-1441A-00	COVER, CLEANER CASE 1	1	1	1	1	1	
22	5BE-1441E-00	COVER, CLEANER CASE 2	1	1	1	1	1	
23	90267-32070	RIVET, BLIND	5	5	5	5	5	
24	90201-03313	WASHER, PLATE	5	5	5	5	5	
25	90183-06023	NUT, SPRING	2	2	2	2	2	
26	95027-06012	BOLT, FLANGE	1	1	1	1	1	
27	5BE-14340-00	VALVE ASSY	1	1	1	1	1	

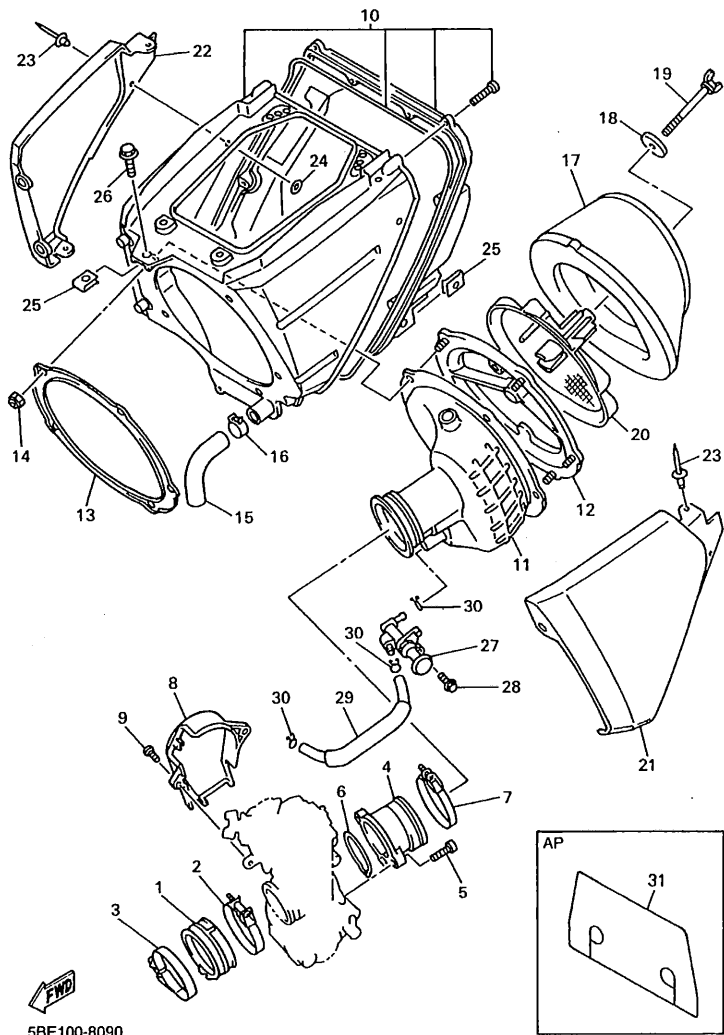

5BE100-8090

FIG. 9 INTAKE

REF. NO.	PART NO.	DESCRIPTION	USA	CAN	OCE	EUR	JPN	REMARKS
28	95027-06016	BOLT, FLANGE	1	1	1	1	1	
29	5BE-14349-00	PIPE	1	1	1	1	1	
30	90467-09103	CLIP	3	3	3	3	3	
31	5BE-14417-00	COVER 1	1	1	1	1	1	AP

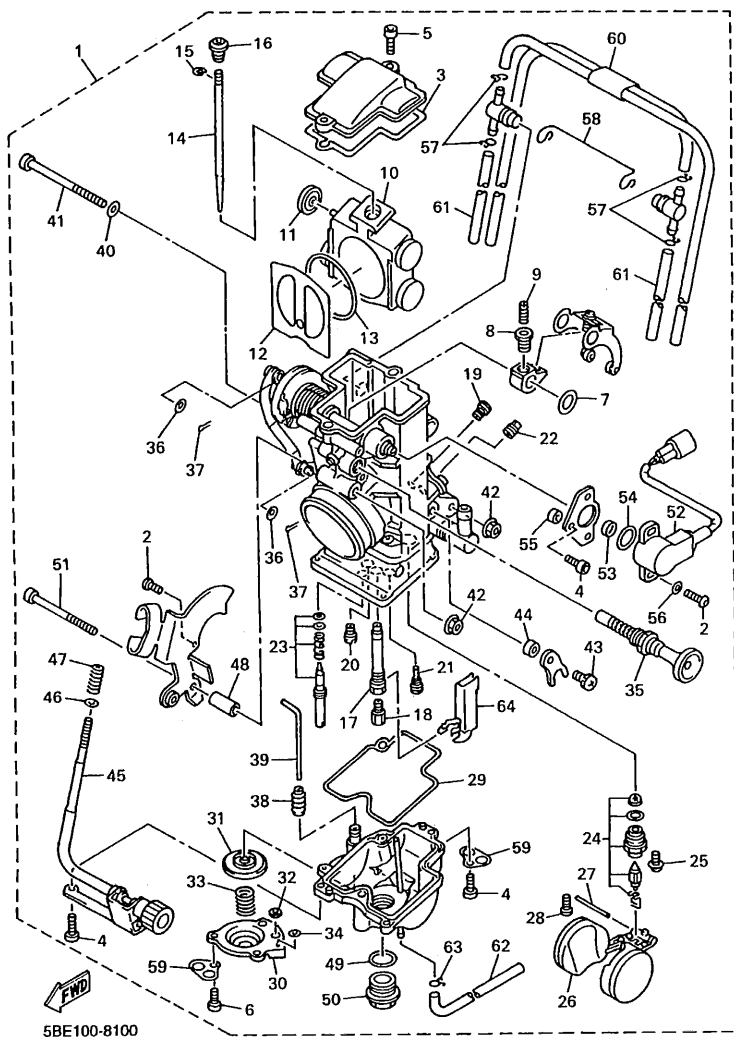
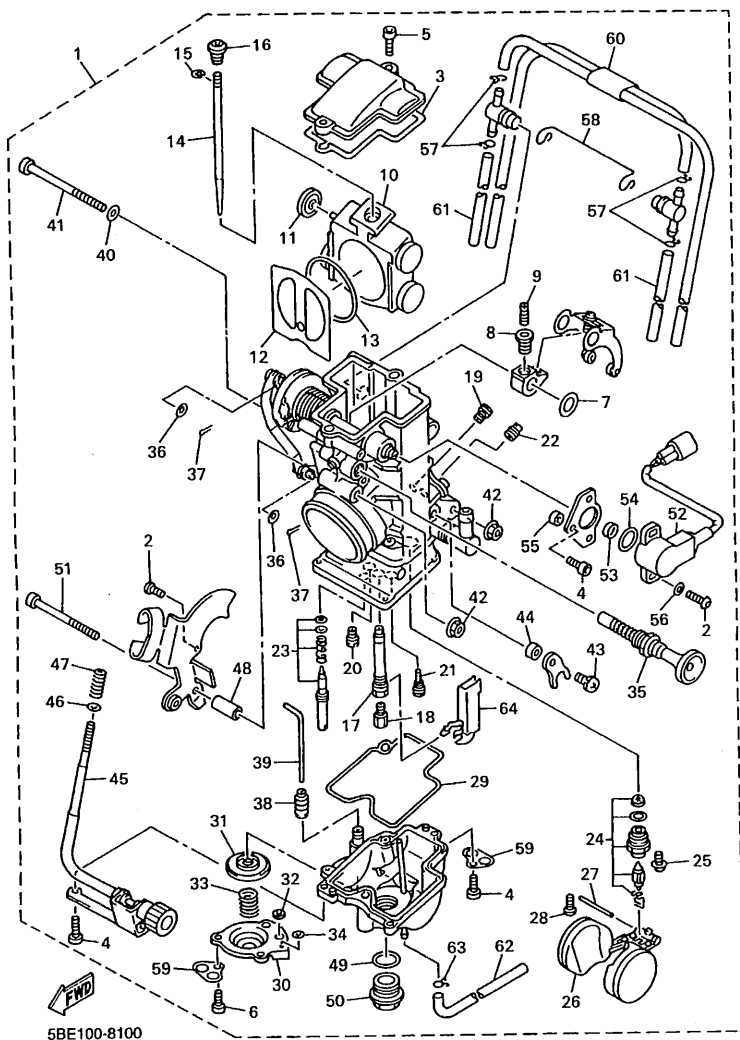

FIG. 10 CARBURETOR

REF. NO.	PART NO.	DESCRIPTION	USA	CAN	OC	EUR	JPN	REMARKS
1	5BE-14101-00	CARBURETOR ASSY 1	1	1	1	1	1	
2	3TJ-14496-40	.BOLT	5	5	5	5	5	
3	5BE-14959-00	.GASKET	1	1	1	1	1	
4	91316-04012	.BOLT	4	4	4	4	4	
5	91316-04012	.BOLT	2	2	2	2	2	
6	91316-04008	.BOLT	3	3	3	3	3	
7	90202-08045	.WASHER, PLATE	1	1	1	1	1	
8	3TJ-14393-40	.NUT, CROWN	1	1	1	1	1	
9	3TJ-14522-40	.SCREW, ADJUST	1	1	1	1	1	
10	5BE-14388-00	.VALVE ASSY	1	1	1	1	1	
11	3TJ-14267-40	.ROLLER	1	1	1	1	1	
12	4FN-14546-00	.VALVE, NEEDLE	1	1	1	1	1	
13	4FN-14997-00	.SEAL	1	1	1	1	1	
14	5BE-14916-DR	.NEEDLE (#DVR)	1	1	1	1	1	STD
*	5BE-14916-CN	.NEEDLE (#CVN)	1	1	1	1	1	AP
	5BE-14916-CP	.NEEDLE (#CVP)	1	1	1	1	1	AP
*	5BE-14916-C1	.NEEDLE (#CVQ)	1	1	1	1	1	AP
	5BE-14916-CR	.NEEDLE (#CVR)	1	1	1	1	1	AP
	5BE-14916-CS	.NEEDLE (#CVS)	1	1	1	1	1	AP
	5BE-14916-CT	.NEEDLE (#CVT)	1	1	1	1	1	AP
	5BE-14916-CU	.NEEDLE (#CVU)	1	1	1	1	1	AP
*	5BE-14916-DN	.NEEDLE (#DVN)	1	1	1	1	1	AP
	5BE-14916-DP	.NEEDLE (#DVP)	1	1	1	1	1	AP
*	5BE-14916-D1	.NEEDLE (#DVQ)	1	1	1	1	1	AP
	5BE-14916-DS	.NEEDLE (#DVS)	1	1	1	1	1	AP
	5BE-14916-DT	.NEEDLE (#DVT)	1	1	1	1	1	AP
	5BE-14916-DU	.NEEDLE (#DVU)	1	1	1	1	1	AP



5BE100-8100

FIG. 10 CARBURETOR

REF. NO.	PART NO.	DESCRIPTION	USA	CAN	OCÉ	EUR	JPN	REMARKS
*14	5BE-14916-EN	.NEEDLE (#EVN)	1	1	1	1	1	AP
	5BE-14916-EP	.NEEDLE (#EVP)	1	1	1	1	1	AP
*	5BE-14916-E1	.NEEDLE (#EVQ)	1	1	1	1	1	AP
	5BE-14916-ER	.NEEDLE (#EVR)	1	1	1	1	1	AP
	5BE-14916-ES	.NEEDLE (#EVS)	1	1	1	1	1	AP
	5BE-14916-ET	.NEEDLE (#EVT)	1	1	1	1	1	AP
	5BE-14916-EU	.NEEDLE (#EVU)	1	1	1	1	1	AP
15	3TJ-14159-40	.CLIP	1	1	1	1	1	
16	5BE-14521-00	.SCREW, ADJUST	1	1	1	1	1	
17	5BE-14947-00	.JET, NEEDLE	1	1	1	1	1	
18	4MX-14943-42	.JET, MAIN (#175)	1	1	1	1	1	STD
	4MX-14943-40	.JET, MAIN (#165)	1	1	1	1	1	AP
	4MX-14943-41	.JET, MAIN (#170)	1	1	1	1	1	AP
	4MX-14943-43	.JET, MAIN (#180)	1	1	1	1	1	AP
	4MX-14943-44	.JET, MAIN (#185)	1	1	1	1	1	AP
	4MX-14943-45	.JET, MAIN (#190)	1	1	1	1	1	AP
	4MX-14943-91	.JET, MAIN (#168)	1	1	1	1	1	AP
	4MX-14943-92	.JET, MAIN (#172)	1	1	1	1	1	AP
	4MX-14943-93	.JET, MAIN (#178)	1	1	1	1	1	AP
	4MX-14943-94	.JET, MAIN (#182)	1	1	1	1	1	AP
	4MX-14943-95	.JET, MAIN (#188)	1	1	1	1	1	AP
19	3TJ-14943-47	.JET (#200)	1	1	1	1	1	
20	3TJ-14948-05	.JET (#45)	1	1	1	1	1	STD
	3TJ-14948-02	.JET (#38)	1	1	1	1	1	AP
	3TJ-14948-03	.JET (#40)	1	1	1	1	1	AP
	3TJ-14948-04	.JET (#42)	1	1	1	1	1	AP
	3TJ-14948-06	.JET (#48)	1	1	1	1	1	AP

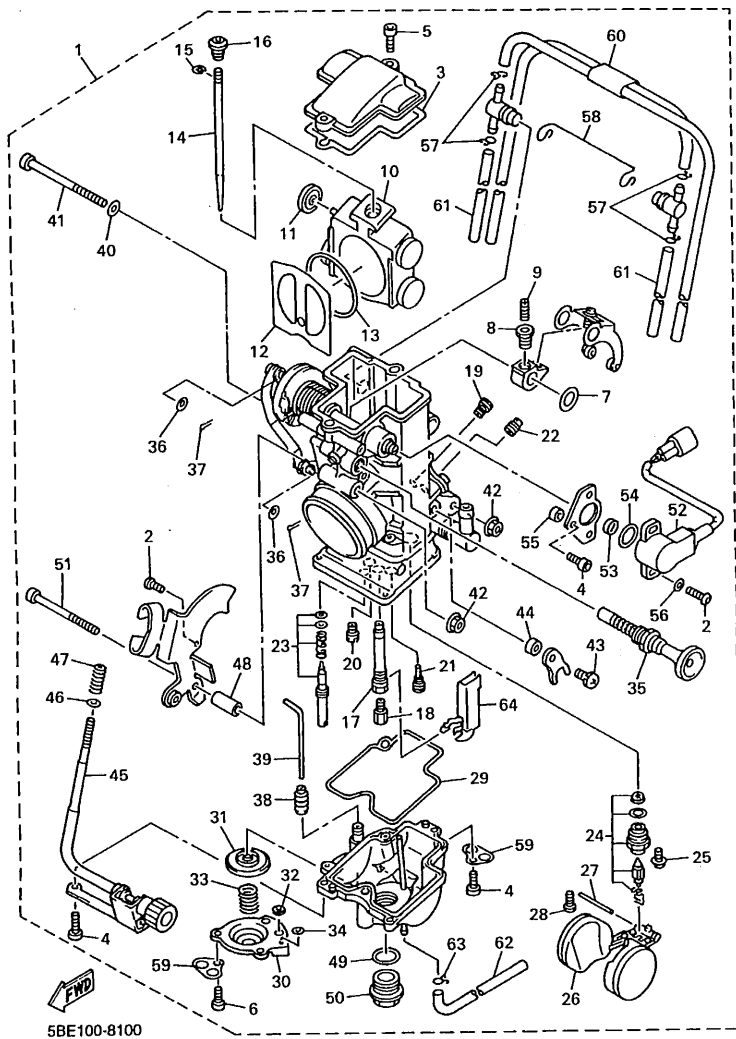
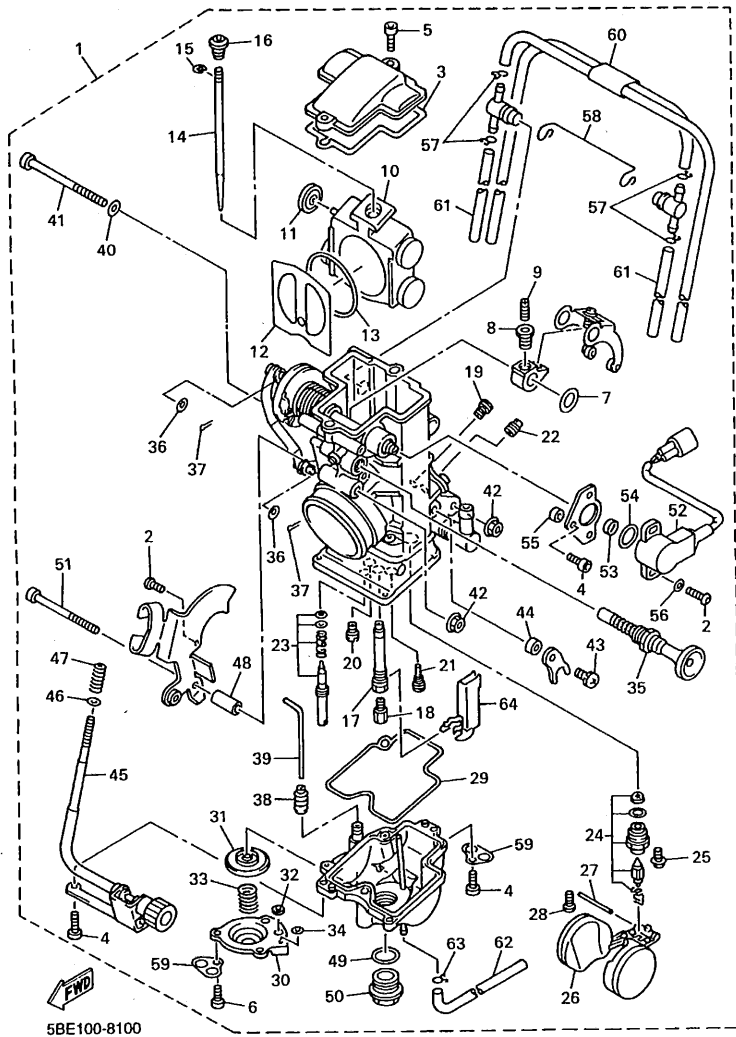

FIG. 10 CARBURETOR

REF. NO.	PART NO.	DESCRIPTION	USA	CAN	OCE	EUR	JPN	REMARKS
20	3TJ-14948-07	.JET (#50)	1	1	1	1	1	AP
	3TJ-14948-08	.JET (#52)	1	1	1	1	1	AP
21	3TJ-1494F-13	.JET (#65)	1	1	1	1	1	STD
	3TJ-1494F-09	.JET (#55)	1	1	1	1	1	AP
	3TJ-1494F-10	.JET (#58)	1	1	1	1	1	AP
	3TJ-1494F-11	.JET (#60)	1	1	1	1	1	AP
	3TJ-1494F-12	.JET (#62)	1	1	1	1	1	AP
	3TJ-1494F-14	.JET (#68)	1	1	1	1	1	AP
	3TJ-1494F-15	.JET (#70)	1	1	1	1	1	AP
	3TJ-1494F-16	.JET (#72)	1	1	1	1	1	AP
	3TJ-1494F-17	.JET (#75)	1	1	1	1	1	AP
22	7A9-14943-27	.JET (#100)	1	1	1	1	1	
23	3TJ-14105-40	.PILOT SCREW SET	1	1	1	1	1	
24	5BE-14107-00	.NEEDLE VALVE SET	1	1	1	1	1	
25	5BE-14216-00	.SCREW	1	1	1	1	1	
26	5BE-14985-00	.FLOAT	1	1	1	1	1	
27	676-14548-00	.PIN, FLOAT ARM	1	1	1	1	1	
28	688-14592-00	.SCREW	1	1	1	1	1	
29	3TJ-14984-40	.GASKET, FLOAT CHAMBER	1	1	1	1	1	
30	3TJ-14293-40	.COVER 1	1	1	1	1	1	
31	5BE-14940-08	.DIAPHRAGM ASSY	1	1	1	1	1	STD
	5BE-14940-05	.DIAPHRAGM ASSY	1	1	1	1	1	AP
	5BE-14940-07	.DIAPHRAGM ASSY	1	1	1	1	1	AP
	5BE-14940-09	.DIAPHRAGM ASSY	1	1	1	1	1	AP
32	3TJ-14536-40	.GASKET	1	1	1	1	1	
33	3TJ-14933-40	.SPRING, DIAPHRAGM	1	1	1	1	1	
34	6H4-14561-00	.O-RING	1	1	1	1	1	



5BE100-8100

FIG. 10 CARBURETOR

REF. NO.	PART NO.	DESCRIPTION	USA	CAN	CE	EUR	JPN	REMARKS
35	5BE-14171-00	.PLUNGER, STARTER	1	1	1	1	1	
36	90202-03052	.WASHER, PLATE	2	2	2	2	2	
37	3TJ-14365-40	.PIN, CLEVIS	2	2	2	2	2	
38	5BE-14968-00	.CAP	1	1	1	1	1	
39	5BE-14379-00	.ROD, STARTER	1	1	1	1	1	
40	5BE-14557-00	.WASHER	1	1	1	1	1	
41	5BE-14162-00	.BOLT, HOLDING	1	1	1	1	1	
42	95704-05500	.NUT, FLANGE	2	2	2	2	2	
43	5BE-14326-00	.SCREW, GUIDE	1	1	1	1	1	
44	5BE-14534-00	.COLLAR	1	1	1	1	1	
45	5BE-14922-00	.SCREW, THROTTLE	1	1	1	1	1	
46	90201-08410	.WASHER, PLATE	1	1	1	1	1	
47	4FN-14934-00	.SPRING, THROTTLE STOP	1	1	1	1	1	
48	5BE-14535-00	.COLLAR	1	1	1	1	1	
49	5BE-14561-00	.O-RING	1	1	1	1	1	
50	5BE-14115-00	.PLUG, SCREW	1	1	1	1	1	
51	91317-05050	.BOLT	1	1	1	1	1	
52	5BE-85885-00	.THROTTLE SENSOR ASSY	1	1	1	1	1	
53	5BE-14449-00	.COLLAR	1	1	1	1	1	
54	5BE-14562-00	.O-RING	1	1	1	1	1	
55	5BE-14265-00	.COLLAR	1	1	1	1	1	
56	5BE-14596-00	.WASHER	2	2	2	2	2	
57	3TJ-14137-40	.CLIP	4	4	4	4	4	
58	5BE-14137-00	.CLIP	1	1	1	1	1	
59	5BE-14146-00	.PLATE	2	2	2	2	2	
60	5BE-14197-00	.PIPE	1	1	1	1	1	
61	5BE-14148-00	.PIPE	2	2	2	2	2	

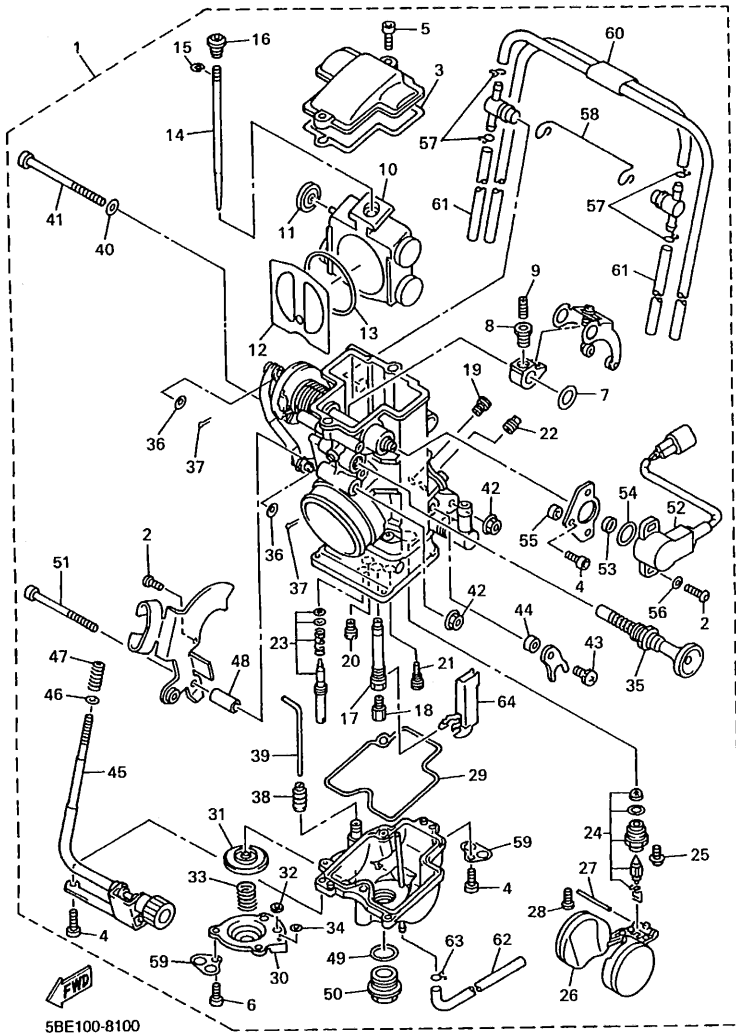

FIG. 10 CARBURETOR

REF. NO.	PART NO.	DESCRIPTION	USA	CAN	OCE	EUR	JPN	REMARKS
62	5BE-14987-00	.HOSE	1	1	1	1	1	
63	5BE-14937-00	.CLIP	1	1	1	1	1	
64	5BE-14346-00	.PLATE	1	1	1	1	1	

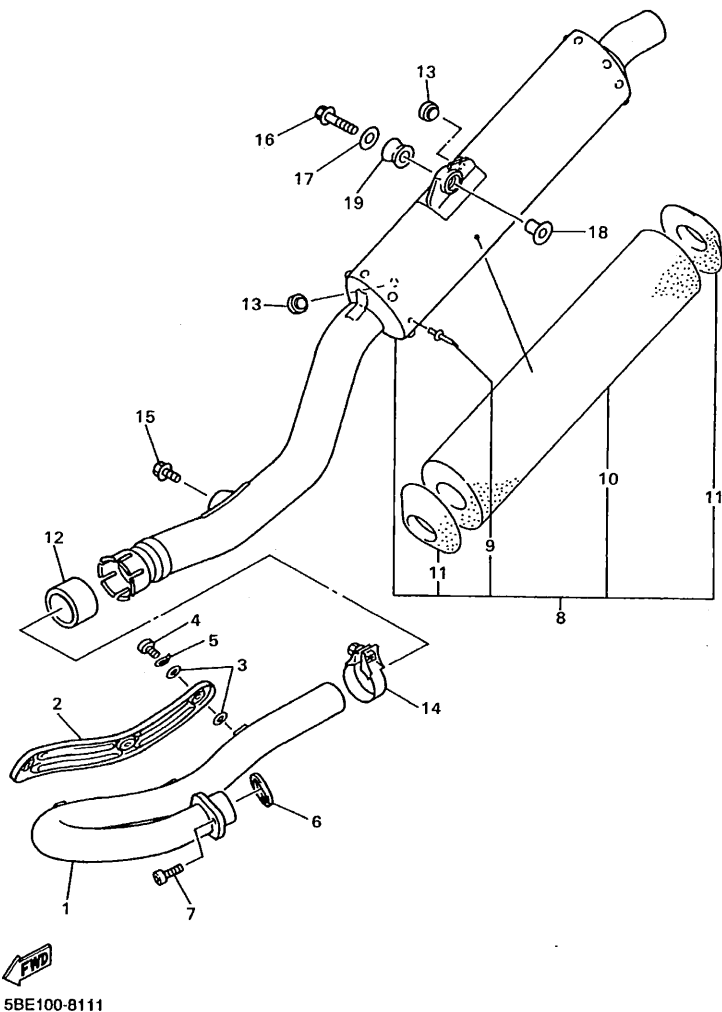

FIG. 11 EXHAUST

REF. NO.	PART NO.	DESCRIPTION	USA	CAN	OC	EUR	JPN	REMARKS
1	5BE-14611-00	PIPE, EXHAUST 1	1	1	1	1	1	
2	5BE-14628-00	PROTECTOR, EXHAUST PIPE	1	1	1	1	1	
3	4BD-14766-00	WASHER, PROTECTOR	6	6	6	6	6	
4	98980-06008	SCREW, BIND	3	3	3	3	3	
5	90206-06090	WASHER, WAVE	3	3	3	3	3	
6	3VD-14613-00	GASKET, EXHAUST PIPE	1	1	1	1	1	
7	91317-08020	BOLT	1	1	1	1	1	
8	5BE-14753-00	SILENCER, EXHAUST	1					
	5BE-14753-10	SILENCER, EXHAUST		1	1	1	1	
*9	90206-48121	.RIVET	8	8	8	8	8	
10	5BE-1469A-00	.FIBER	1					
	5BE-1469A-10	.FIBER		1	1	1	1	
*11	5BE-1469E-00	.FIBER 2	2	2	2	2	2	
12	3GW-14714-00	GASKET, MUFFLER	1	1	1	1	1	
13	22W-24181-00	DAMPER, LOCATING 1	2	2	2	2	2	
14	5BE-14788-00	BAND, SILENCER	1	1	1	1	1	
15	95827-08012	BOLT, FLANGE	1	1	1	1	1	
16	95827-08030	BOLT, FLANGE	1	1	1	1	1	
17	90201-081R9	WASHER, PLATE	1	1	1	1	1	
18	90387-0814J	COLLAR	1	1	1	1	1	
19	5BE-14747-00	DAMPER, MUFFLER	1	1	1	1	1	

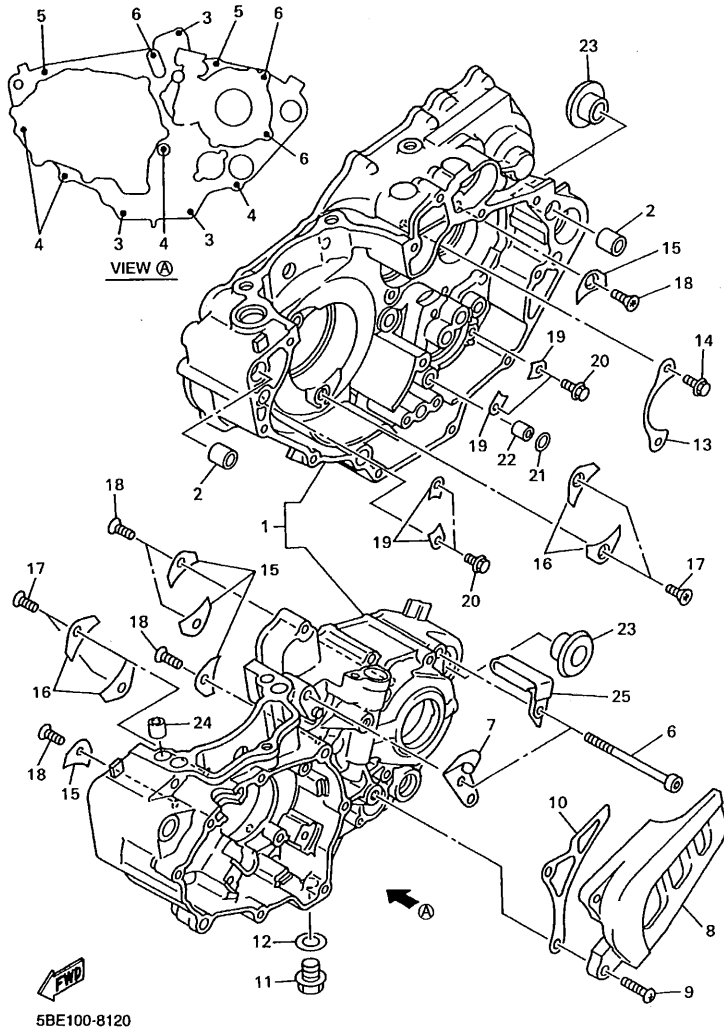
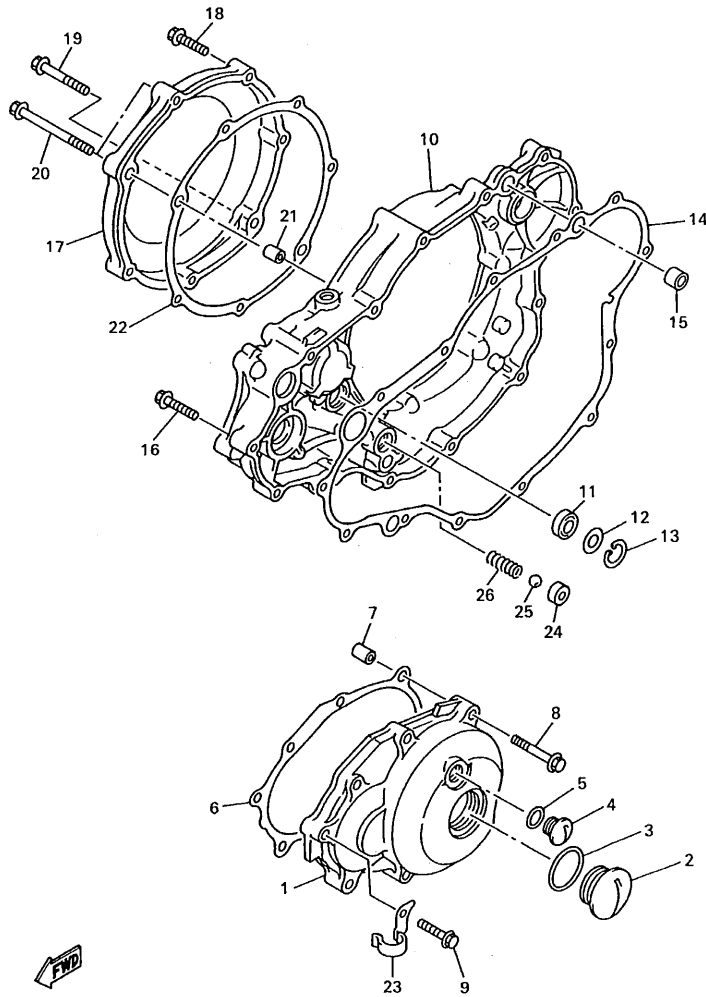

FIG. 12 CRANKCASE

REF. NO.	PART NO.	DESCRIPTION	USA	CAN	OC	EUR	JPN	REMARKS
1	5BE-15150-00	CRANKCASE ASSY	1	1	1	1	1	
2	99530-14016	PIN, DOWEL	2	2	2	2	2	
3	91317-06040	BOLT	3	3	3	3	3	
4	91317-06050	BOLT	4	4	4	4	4	
5	91317-06060	BOLT	2	2	2	2	2	
6	91317-06075	BOLT	3	3	3	3	3	
7	5BE-15441-00	HOLDER, CLUTCH CABLE	1	1	1	1	1	
8	5BE-15421-00	COVER, CRANKCASE 2	1	1	1	1	1	
9	98507-06025	SCREW, PAN HEAD	2	2	2	2	2	
10	5BE-17466-00	GUIDE, CHAIN	1	1	1	1	1	
11	90340-12059	PLUG, STRAIGHT SCREW	1	1	1	1	1	
12	90430-12213	GASKET	1	1	1	1	1	
13	4L0-17471-00	PLATE, COVER	1	1	1	1	1	
14	90105-06553	BOLT, WASHER BASED	2	2	2	2	2	
15	4JT-15381-01	PLATE, BEARING COVER	5	5	5	5	5	
16	5BE-15383-00	PLATE, BEARING COVER	4	4	4	4	4	
17	90149-06286	SCREW	4	4	4	4	4	
18	90149-06326	SCREW	5	5	5	5	5	
19	5DH-18562-00	PLATE, STOPPER 2	4	4	4	4	4	
20	90105-06553	BOLT, WASHER BASED	4	4	4	4	4	
21	93210-10197	O-RING	1	1	1	1	1	
22	99530-10114	PIN, DOWEL	1	1	1	1	1	
23	90387-1712Y	COLLAR	2	2	2	2	2	
24	99530-10116	PIN, DOWEL	2	2	2	2	2	
25	90461-10136	CLAMP	1	1	1	1	1	

FIG. 13 CRANKCASE COVER 1



5BE100-8130

REF. NO.	PART NO.	DESCRIPTION	USA	CAN	OE	EUR	JPN	REMARKS
1	5BE-15411-00	COVER, CRANKCASE 1	1	1	1	1	1	
2	90340-32123	PLUG, STRAIGHT SCREW	1	1	1	1	1	
3	93210-32172	O-RING	1	1	1	1	1	
4	90340-14128	PLUG, STRAIGHT SCREW	1	1	1	1	1	
5	93210-14369	O-RING	1	1	1	1	1	
6	5BE-15451-00	GASKET, CRANKCASE COVER 1	1	1	1	1	1	
7	99530-08016	PIN, DOWEL	2	2	2	2	2	
8	95027-06040	BOLT, FLANGE	2	2	2	2	2	
9	95027-06030	BOLT, FLANGE	6	6	6	6	6	
10	5BE-15431-00	COVER, CRANKCASE 3	1	1	1	1	1	
11	93101-14164	OIL SEAL	1	1	1	1	1	
12	90201-15701	WASHER, PLATE (1.0T)	1	1	1	1	1	
13	99009-22500	CIRCLIP	1	1	1	1	1	
14	5BE-15462-00	GASKET, CRANKCASE COVER 3	1	1	1	1	1	
15	91812-16001	PIN, DOWEL	2	2	2	2	2	
16	95027-06030	BOLT, FLANGE	10	10	10	10	10	
17	5BE-15415-00	COVER, GENERATOR	1	1	1	1	1	
18	95027-06030	BOLT, FLANGE	4	4	4	4	4	
19	95027-06040	BOLT, FLANGE	1	1	1	1	1	
20	90105-065A1	BOLT, WASHER BASED	2	2	2	2	2	
21	99530-08016	PIN, DOWEL	2	2	2	2	2	
22	5BE-15453-00	GASKET	1	1	1	1	1	
23	90462-10241	CLAMP	1	1	1	1	1	
24	583-13113-00	SEAT, CHECK BALL	1	1	1	1	1	
25	93503-08007	BALL	1	1	1	1	1	
26	90501-043E0	SPRING, COMPRESSION	1	1	1	1	1	

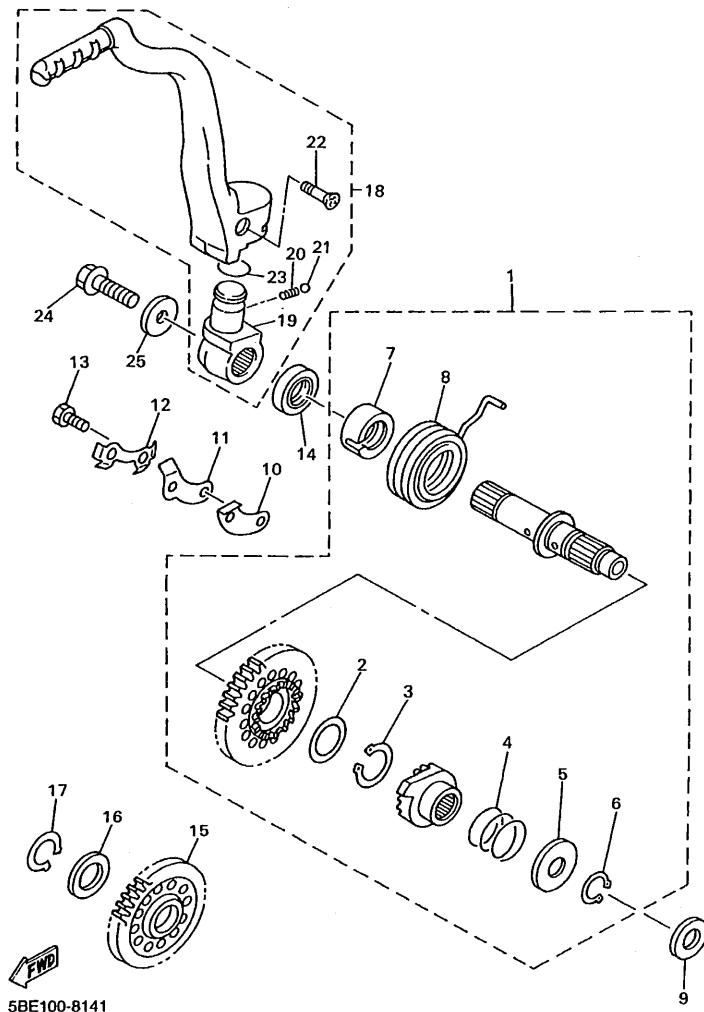
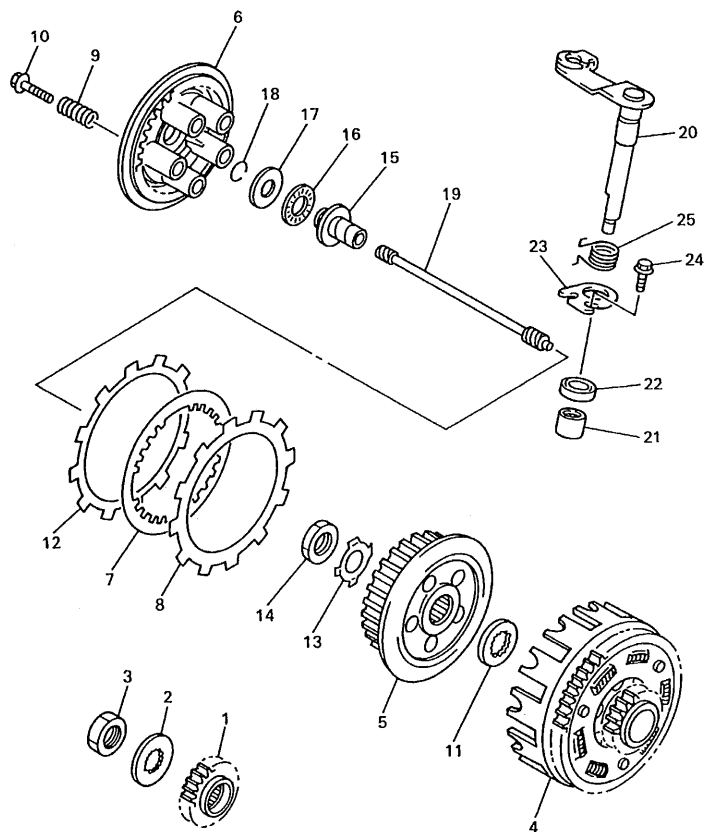

FIG. 14 STARTER

REF. NO.	PART NO.	DESCRIPTION	USA	CAN	OCÉ	EUR	JPN	REMARKS
1	5BE-15601-00	KICK SHAFT ASSY	1	1	1	1	1	
2	90201-20685	.WASHER, PLATE (0.5T)	1	1	1	1	1	
3	93410-20038	.CIRCLIP	1	1	1	1	1	
4	90501-16107	.SPRING, COMPRESSION	1	1	1	1	1	
5	90201-167P7	.WASHER, PLATE	1	1	1	1	1	
6	99009-16400	.CIRCLIP	1	1	1	1	1	
7	5BE-15664-00	.GUIDE, SPRING	1	1	1	1	1	
8	90508-30743	.SPRING, TORSION	1	1	1	1	1	
9	90201-162H4	WASHER, PLATE	1	1	1	1	1	
10	5BE-15668-00	STOPPER	1	1	1	1	1	
11	5BE-15674-00	GUIDE, RATCHET WHEEL	1	1	1	1	1	
12	5BE-15686-00	WASHER, LOCK	1	1	1	1	1	
13	97027-06016	BOLT	2	2	2	2	2	
14	93102-20108	OIL SEAL	1	1	1	1	1	
15	5BE-15651-00	GEAR, KICK IDLE	1	1	1	1	1	
16	90201-20276	WASHER, PLATE (1.0T)	1	1	1	1	1	
17	99009-20400	CIRCLIP	1	1	1	1	1	
18	5BE-15620-00	KICK CRANK ASSY	1	1	1	1	1	
*19	3SP-15621-02	.BOSS, KICK CRANK	1	1	1	1	1	
*20	90501-13720	.SPRING, COMPRESSION	1	1	1	1	1	
*21	93501-04011	.BALL	1	1	1	1	1	
*22	90152-06010	.SCREW	1	1	1	1	1	
*23	93210-19216	.O-RING	1	1	1	1	1	
24	90105-08752	BOLT, WASHER BASED	1	1	1	1	1	
25	90201-087A9	WASHER, PLATE	1	1	1	1	1	



5BE100-8150

FIG. 15 CLUTCH

REF. NO.	PART NO.	DESCRIPTION	USA	CAN	OCE	EUR	JPN	REMARKS
1	5BE-16111-00	GEAR, PRIMARY DRIVE	1	1	1	1	1	
2	90215-21290	WASHER, LOCK	1	1	1	1	1	
3	90179-20255	NUT	1	1	1	1	1	
4	5BE-16150-00	PRIMARY DRIVEN GEAR COMP.	1	1	1	1	1	
5	2JN-16371-00	BOSS, CLUTCH	1	1	1	1	1	
6	3YF-16351-00	PLATE, PRESSURE 1	1	1	1	1	1	
7	360-16325-00	PLATE, CLUTCH 2	7	7	7	7	7	
8	5BE-16321-00	PLATE, FRICTION	7	7	7	7	7	
9	90501-244L9	SPRING, COMPRESSION	5	5	5	5	5	
10	90159-06092	SCREW, WITH WASHER	5	5	5	5	5	
11	2JN-16154-00	PLATE, THRUST 1	1	1	1	1	1	
12	5BE-16331-00	PLATE, FRICTION 2	1	1	1	1	1	
13	90215-20231	WASHER, LOCK	1	1	1	1	1	
14	90170-20327	NUT	1	1	1	1	1	
15	5BE-16356-00	ROD, PUSH 1	1	1	1	1	1	
16	93340-21505	BEARING	1	1	1	1	1	
17	90201-125L6	WASHER, PLATE	1	1	1	1	1	
18	93440-10085	CIRCLIP	1	1	1	1	1	
19	5BE-16357-00	ROD, PUSH 2	1	1	1	1	1	
20	5BE-16381-00	PUSH LEVER COMP.	1	1	1	1	1	
21	93315-11206	BEARING	1	1	1	1	1	
22	93102-12224	OIL SEAL	1	1	1	1	1	
23	4JT-16384-00	PLATE, SEAT	1	1	1	1	1	
24	95027-06010	BOLT, FLANGE	1	1	1	1	1	
25	90508-142B5	SPRING, TORSION	1	1	1	1	1	

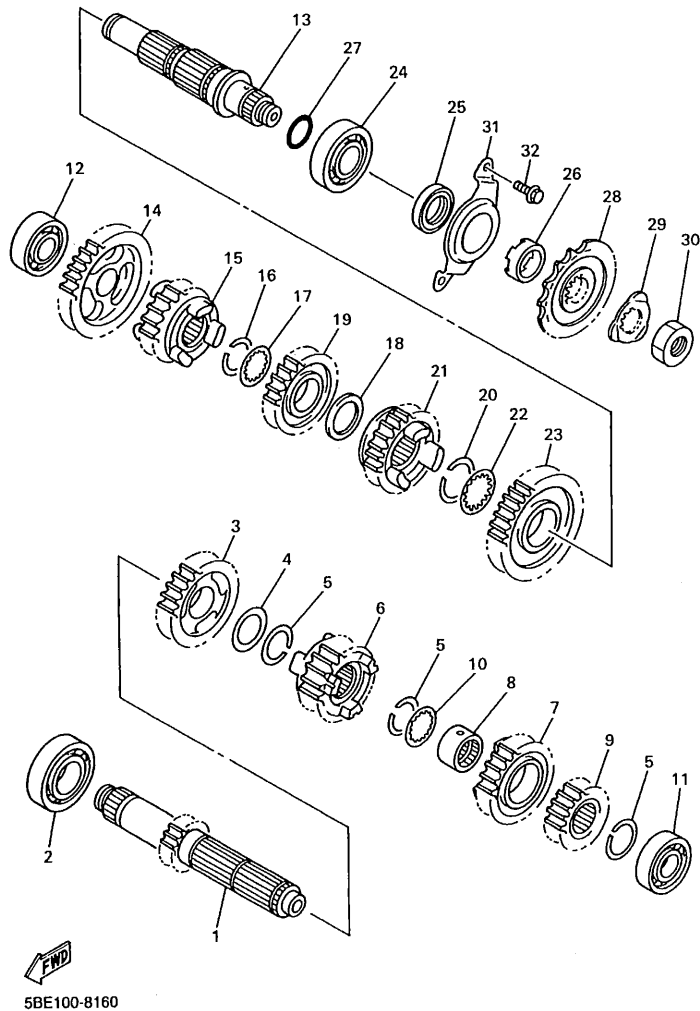
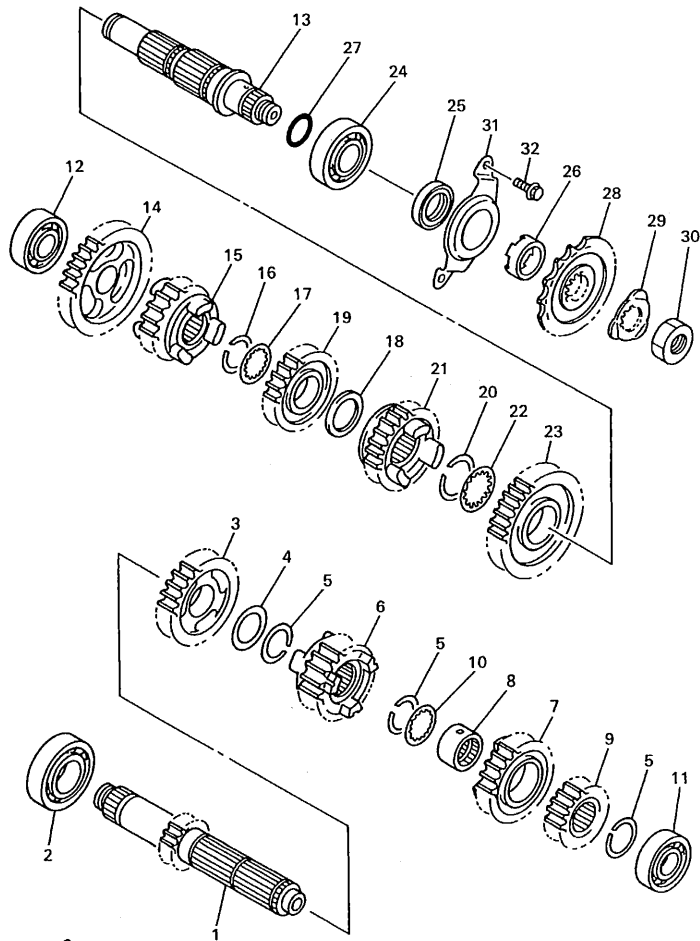

FIG. 16 TRANSMISSION

REF. NO.	PART NO.	DESCRIPTION	USA	CAN	OCE	EUR	JPN	REMARKS
1	5BE-17411-00	AXLE, MAIN	1	1	1	1	1	
2	93306-20532	BEARING	1	1	1	1	1	
3	5BE-17151-00	GEAR, 5TH PINION	1	1	1	1	1	
4	90201-253K0	WASHER, PLATE (T=1.0)	1	1	1	1	1	
5	93440-25084	CIRCLIP	3	3	3	3	3	
6	5BE-17131-00	GEAR, 3RD PINION	1	1	1	1	1	
7	5BE-17141-00	GEAR, 4TH PINION	1	1	1	1	1	
8	90387-2113G	COLLAR	1	1	1	1	1	
9	5BE-17121-00	GEAR, 2ND PINION	1	1	1	1	1	
10	90209-21332	WASHER	1	1	1	1	1	
11	93306-00431	BEARING	1	1	1	1	1	
12	93306-00426	BEARING	1	1	1	1	1	
13	5BE-17421-00	AXLE, DRIVE	1	1	1	1	1	
14	5BE-17211-00	GEAR, 1ST WHEEL	1	1	1	1	1	
15	5BE-17251-00	GEAR, 5TH WHEEL	1	1	1	1	1	
16	93440-25084	CIRCLIP	1	1	1	1	1	
17	90209-21332	WASHER	1	1	1	1	1	
18	90201-253K0	WASHER, PLATE (T=1.0)	1	1	1	1	1	
19	5BE-17231-00	GEAR, 3RD WHEEL	1	1	1	1	1	
20	93440-28062	CIRCLIP	1	1	1	1	1	
21	5BE-17241-00	GEAR, 4TH WHEEL	1	1	1	1	1	
22	90209-26348	WASHER	1	1	1	1	1	
23	5BE-17221-00	GEAR, 2ND WHEEL	1	1	1	1	1	
24	93306-20593	BEARING	1	1	1	1	1	
25	93102-32480	OIL SEAL	1	1	1	1	1	
26	90387-2513F	COLLAR	1	1	1	1	1	
27	93210-22298	O-RING	1	1	1	1	1	



FWD

5BE100-8160

FIG. 16 TRANSMISSION

REF. NO.	PART NO.	DESCRIPTION	USA	CAN	OCÉ	EUR	JPN	REMARKS
28	9383E-14210	SPROCKET, DRIVE (14T)	1	1	1	1	1	UR STD
29	90215-21256	WASHER, LOCK	1	1	1	1	1	
30	90179-20255	NUT	1	1	1	1	1	
31	5BE-17471-00	PLATE, COVER	1	1	1	1	1	
32	90105-06553	BOLT, WASHER BASED	2	2	2	2	2	

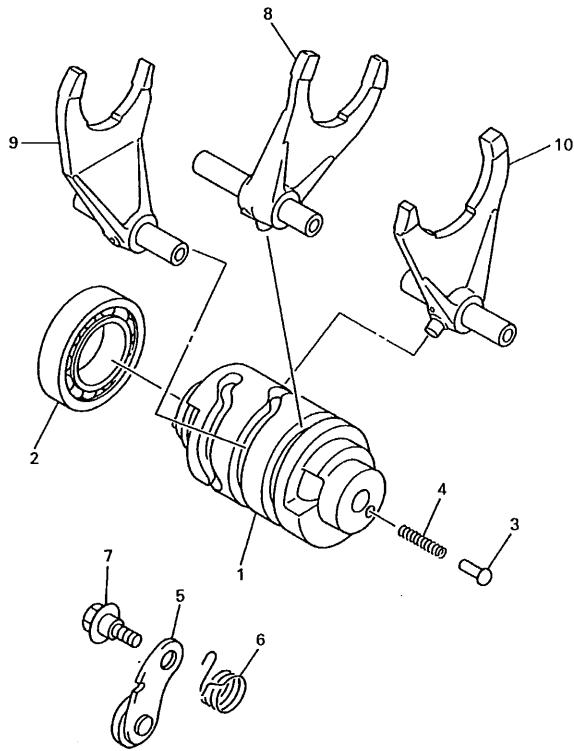
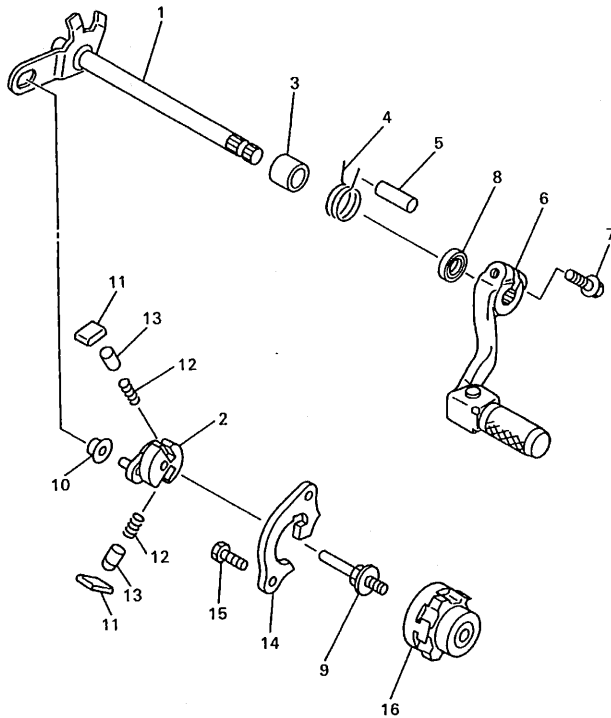

FIG. 17 SHIFT CAM. FORK

REF. NO.	PART NO.	DESCRIPTION	USA	CAN	OCE	EUR	JPN	REMARKS
1	5BE-18541-00	CAM, SHIFT	1	1	1	1	1	
2	93306-90501	BEARING	1	1	1	1	1	
3	4BA-18542-00	POINT, NEUTRAL	1	1	1	1	1	
4	90501-06022	SPRING, COMPRESSION	1	1	1	1	1	
5	3XK-18140-00	STOPPER LEVER ASSY	1	1	1	1	1	
6	90508-26561	SPRING, TORSION	1	1	1	1	1	
7	90109-063F8	BOLT	1	1	1	1	1	
8	5BE-18501-00	FORK, SHIFT 1	1	1	1	1	1	
9	5BE-18502-00	FORK, SHIFT 2	1	1	1	1	1	
10	5BE-18503-00	FORK, SHIFT 3	1	1	1	1	1	



5BE100-8170



5BE100-8180

FIG. 18 SHIFT SHAFT

REF. NO.	PART NO.	DESCRIPTION	USA	CAN	OCE	EUR	JPN	REMARKS
1	3XK-18101-02	SHIFT SHAFT ASSY	1	1	1	1	1	
2	3XK-18122-00	LEVER, SHIFT 2	1	1	1	1	1	
3	90387-124F4	COLLAR	1	1	1	1	1	
4	90508-291A8	SPRING, TORSION	1	1	1	1	1	
5	93608-33046	PIN, DOWEL	1	1	1	1	1	
6	5BE-18110-00	SHIFT PEDAL ASSY	1	1	1	1	1	
7	95027-06020	BOLT, FLANGE	1	1	1	1	1	
8	93102-12106	OIL SEAL (SD 12-22-5 HS)	1	1	1	1	1	
9	3XJ-18173-00	PIN, SHIFT	1	1	1	1	1	
10	3XJ-18178-00	ROLLER, SHIFT LEVER	1	1	1	1	1	
11	3XJ-18182-00	PAWL, SHIFTER	2	2	2	2	2	
12	90501-052G5	SPRING, COMPRESSION	2	2	2	2	2	
13	3XJ-18184-00	PIN, PAWL	2	2	2	2	2	
14	5BE-18172-00	GUIDE, SHIFT	1	1	1	1	1	
15	90101-06664	BOLT	2	2	2	2	2	
16	4EW-18185-00	SEGMENT	1	1	1	1	1	

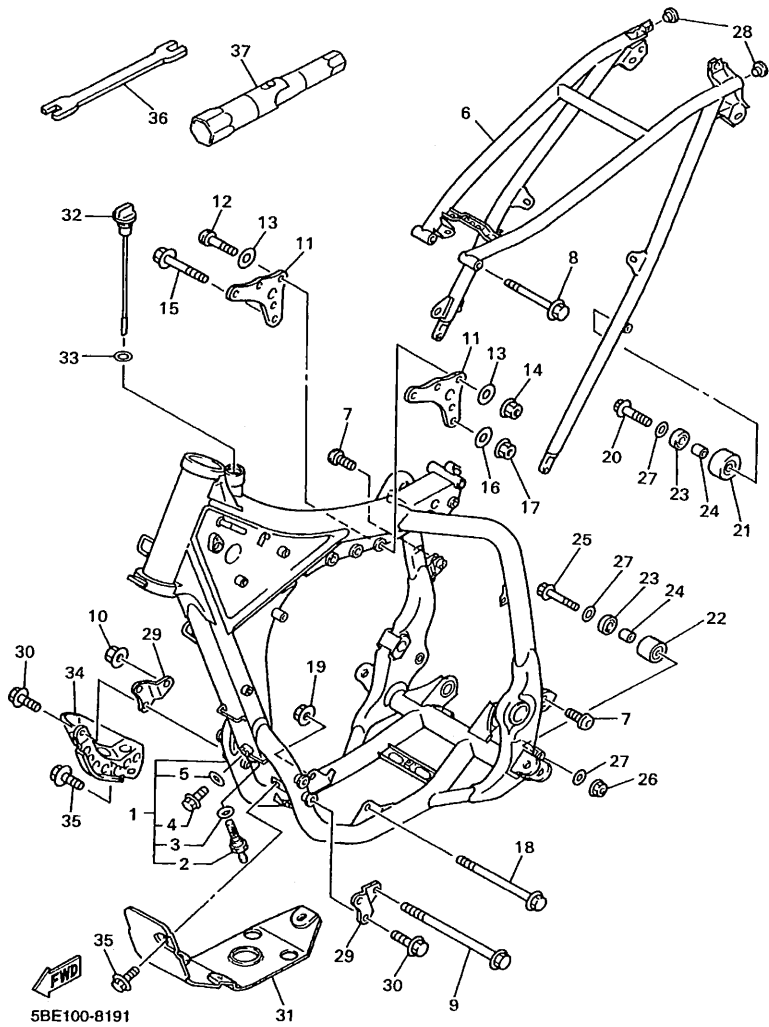
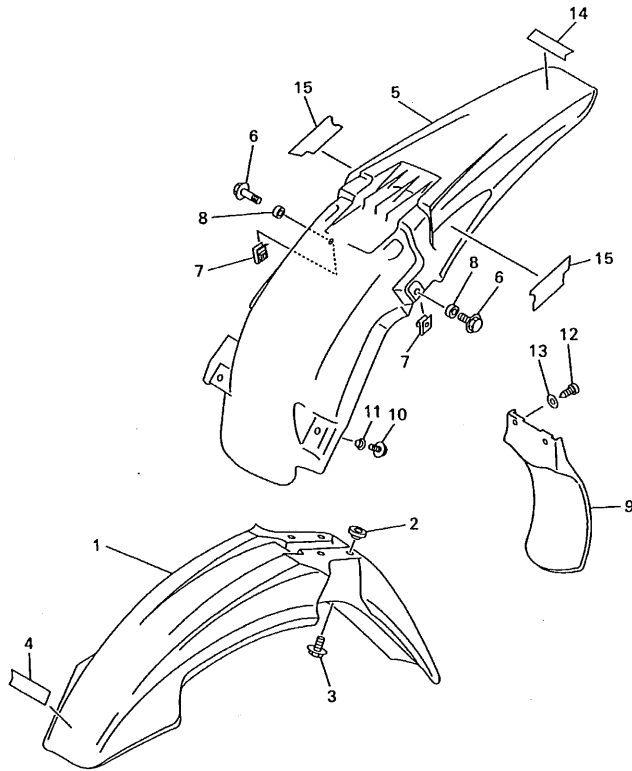

FIG. 19 FRAME

REF. NO.	PART NO.	DESCRIPTION	USA	CAN	OC	EUR	JPN	REMARKS
1	5BE-21101-00-P0	FRONT FRAME COMP.	1	1	1			DPBMC
	5BE-21101-00-7B	FRONT FRAME COMP.				1	1	BIB2
* 2	5BE-21756-00	.NET, FILTER	1	1	1	1	1	
* 3	90430-18130	.GASKET	1	1	1	1	1	
* 4	95827-08012	.BOLT, FLANGE	1	1	1	1	1	
* 5	90430-08119	.GASKET	1	1	1	1	1	
6	5BE-21190-00-P0	REAR FRAME COMP.	1	1	1			DPBMC
	5BE-21190-00-7B	REAR FRAME COMP.				1	1	BIB2
7	90110-08096	BOLT, HEXAGON SOCKET HEAD	2	2	2	2	2	
8	90105-08099	BOLT, WASHER BASED	1	1	1	1	1	
9	95817-10160	BOLT, FLANGE	1	1	1	1	1	
10	95617-10200	NUT, SELF-LOCKING	1	1	1	1	1	
11	5BE-21425-00	BRACKET, REAR UPPER 1	2	2	2	2	2	
12	92017-08055	BOLT, BUTTON HEAD	3	3	3	3	3	
13	90201-086P8	WASHER, PLATE	6	6	6	6	6	
14	95607-08200	NUT, SELF-LOCKING	3	3	3	3	3	
15	95027-10055	BOLT, FLANGE	1	1	1	1	1	
16	92907-10200	WASHER, PLAIN	1	1	1	1	1	
17	95617-10200	NUT, SELF-LOCKING	1	1	1	1	1	
18	90105-10733	BOLT, WASHER BASED	1	1	1	1	1	
19	95617-10200	NUT, SELF-LOCKING	1	1	1	1	1	
20	95027-08040	BOLT, FLANGE	1	1	1	1	1	
21	3JD-22178-10	TENSIONER	1	1	1	1	1	
22	4EW-22178-00	TENSIONER	1	1	1	1	1	
23	93300-60804	BEARING	2	2	2	2	2	
24	90387-086N4	COLLAR	2	2	2	2	2	
25	95027-08065	BOLT, FLANGE	1	1	1	1	1	

FIG. 20 FENDER



REF. NO.	PART NO.	DESCRIPTION	USA	CAN	OC	EUR	JPN	REMARKS
1	4DA-21511-20	FENDER, FRONT	1	1	1			
	4DA-21511-00	FENDER, FRONT				1	1	
2	3JD-21748-00	COLLAR	4	4	4	4	4	
3	90119-06096	BOLT, WITH WASHER	4	4	4	4	4	
4	99241-00080	EMBLEM, YAMAHA	1	1	1			
	99244-00080	EMBLEM, YAMAHA				1	1	
5	5BE-21611-10	FENDER, REAR	1	1	1			
	5BE-21611-00	FENDER, REAR				1	1	
6	95027-06012	BOLT, FLANGE	2	2	2	2	2	
7	90183-06023	NUT, SPRING	2	2	2	2	2	
8	90387-0701A	COLLAR	2	2	2	2	2	
9	5BE-21642-00	GUARD, FLAP	1	1	1	1	1	
10	95027-06014	BOLT, FLANGE	2	2	2	2	2	
11	90387-0600F	COLLAR	2	2	2	2	2	
12	97707-60016	SCREW, TAPPING	2	2	2	2	2	
13	90201-06557	WASHER, PLATE	2	2	2	2	2	
14	99241-00080	EMBLEM, YAMAHA	1		1			
	99244-00080	EMBLEM, YAMAHA				1	1	
15	5BE-2163G-00	EMBLEM 1	2	2	2			
	5BE-2163G-10	EMBLEM 1				2	2	

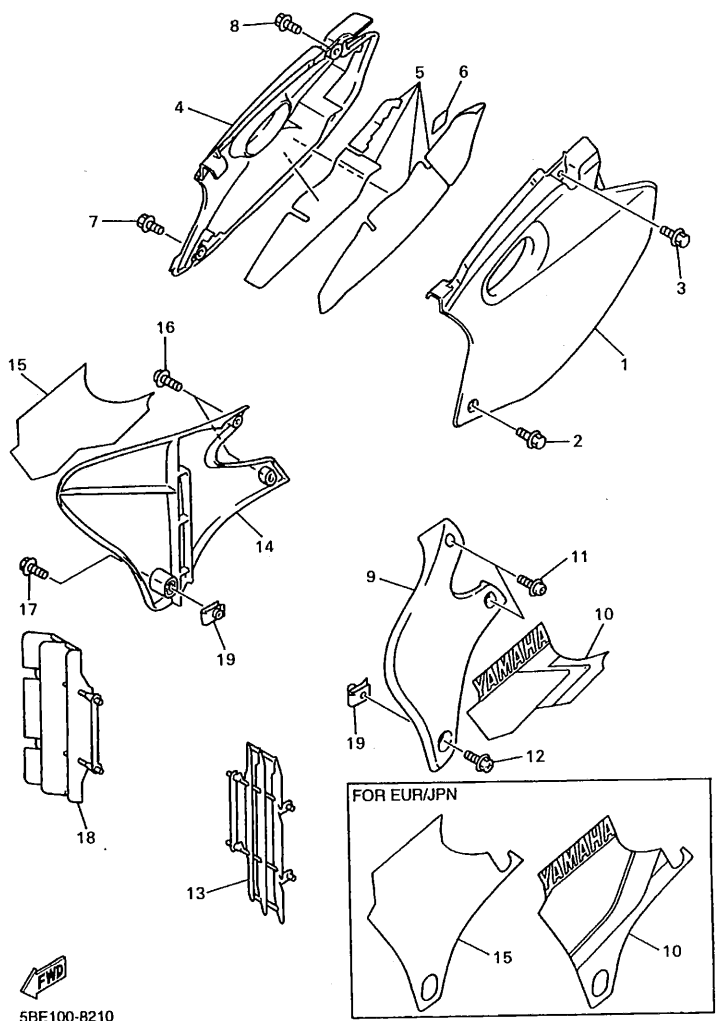

5BE100-8200



5BE100-8210

FIG. 21 SIDE COVER

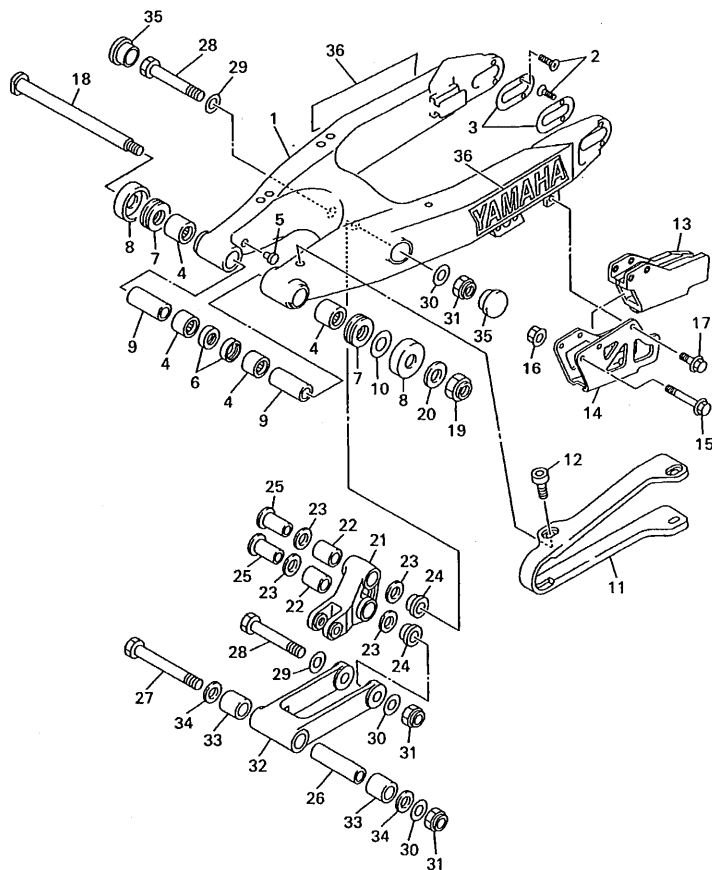
REF. NO.	PART NO.	DESCRIPTION	USA	CAN	OC	EUR	JPN	REMARKS
1	5BE-21711-00	COVER, SIDE 1	1	1	1	1	1	
2	95827-06016	BOLT, FLANGE	1	1	1	1	1	
3	90119-08238	BOLT, WITH WASHER	1	1	1	1	1	
4	5BE-21721-00	COVER, SIDE 2	1	1	1	1	1	
5	5BE-2174A-00	INSULATOR, SIDE COVER	1	1	1	1	1	
6	3FY-21575-01	SEAL 1	1	1	1	1	1	
7	95827-06016	BOLT, FLANGE	1	1	1	1	1	
8	90119-08238	BOLT, WITH WASHER	1	1	1	1	1	
9	5BE-21731-10	COVER, SIDE 3	1	1	1			
	5BE-21731-00	COVER, SIDE 3				1	1	
10	5BE-2173E-01	GRAPHIC 1	1	1	1			
	5BE-2173E-11	GRAPHIC 1					1	1
11	90159-06182	SCREW, WITH WASHER	2	2	2	2	2	
12	90159-06078	SCREW, WITH WASHER	1	1	1	1	1	
13	4EW-2172A-10	PANEL 1	1	1	1	1	1	
14	5BE-21741-10	COVER, SIDE 4	1	1	1			
	5BE-21741-00	COVER, SIDE 4				1	1	
15	5BE-2173F-01	GRAPHIC 2	1	1	1			
	5BE-2173F-11	GRAPHIC 2					1	1
16	90159-06182	SCREW, WITH WASHER	2	2	2	2	2	
17	90159-06078	SCREW, WITH WASHER	1	1	1	1	1	
18	4EW-2172A-10	PANEL 1	1	1	1	1	1	
19	90183-06069	NUT, SPRING	2	2	2	2	2	



5BE100-8220

FIG. 22 REAR ARM

REF. NO.	PART NO.	DESCRIPTION	USA	CAN	OC	EUR	JPN	REMARKS
1	5BE-22110-00	REAR ARM COMP.	1	1	1	1	1	
2	90151-04048	SCREW, COUNTERSUNK	4	4	4	4	4	
3	4SS-22355-00	PATCH	2	2	2	2	2	
4	93317-22262	BEARING	4	4	4	4	4	
5	90338-16148	PLUG	2	2	2	2	2	
6	93106-22019	OIL SEAL (DC 22-28-8)	2	2	2	2	2	
7	93342-22215	BEARING	2	2	2	2	2	
8	5DH-22129-00	COVER, THRUST 2	2	2	2	2	2	
9	90387-1712R	COLLAR	2	2	2	2	2	
10	156-22127-00	SHIM (0.3T)	1	1	1	1	1	UN
11	4EW-22151-20	SEAL, GUARD	1	1	1	1	1	
12	90110-05201	BOLT, HEXAGON SOCKET HEAD	4	4	4	4	4	
13	4XM-22199-00	SUPPORT, CHAIN	1	1	1	1	1	
14	4XM-22128-00	COVER, THRUST 1	1	1	1	1	1	
15	95027-06050	BOLT, FLANGE	2	2	2	2	2	
16	90179-06568	NUT	2	2	2	2	2	
17	95027-06010	BOLT, FLANGE	1	1	1	1	1	
18	5DH-22141-00	SHAFT, PIVOT	1	1	1	1	1	
19	90185-16127	NUT, SELF-LOCKING	1	1	1	1	1	
20	90201-164H4	WASHER, PLATE	1	1	1	1	1	
21	5DH-2217A-00	ARM, RELAY	1	1	1	1	1	
22	93315-32056	BEARING	2	2	2	2	2	
23	93109-20076	OIL SEAL	4	4	4	4	4	
24	90387-164N2	COLLAR	2	2	2	2	2	
25	90387-164N3	COLLAR	2	2	2	2	2	
26	90387-167Y9	COLLAR	1	1	1	1	1	
27	90109-147F2	BOLT	1	1	1	1	1	

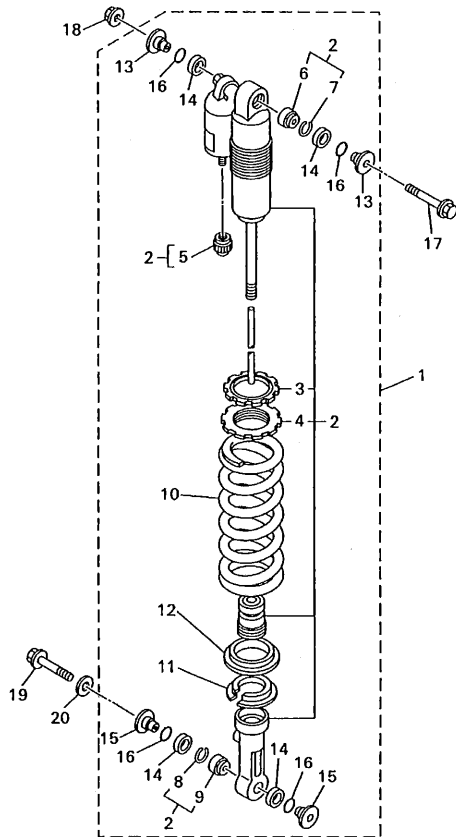

FWD
5BE100-8230

FIG. 23 REAR SUSPENSION

REF. NO.	PART NO.	DESCRIPTION	USA	CAN	OCE	EUR	JPN	REMARKS
1	5BE-22210-00	SHOCK ABSORBER ASSY, REAR	1					
	5BE-22210-30	SHOCK ABSORBER ASSY, REAR		1				
	5BE-22210-10	SHOCK ABSORBER ASSY, REAR			1	1		
	5BE-22210-20	SHOCK ABSORBER ASSY, REAR					1	
2	5BE-22201-00	.DAMPER SUB ASSY	1					
	5BE-22201-30	.DAMPER SUB ASSY		1				
	5BE-22201-10	.DAMPER SUB ASSY			1	1		
	5BE-22201-20	.DAMPER SUB ASSY					1	
3	3SP-22234-00	..GUIDE, SPRING 3	1	1	1	1	1	
4	3SP-22213-00	..SEAT, SPRING UPPER	1	1	1	1	1	
5	509-23184-L0	..CAP, AIR VALVE	1	1	1	1	1	
6	4JX-22226-00	..BUSH, SHOCK ABSORBER LOWER	1	1	1	1	1	
7	5DH-23183-00	..CIRCLIP	1	1	1	1	1	
8	5DH-23183-00	..CIRCLIP	1	1	1	1	1	
9	4JX-22226-00	..BUSH, SHOCK ABSORBER LOWER	1	1	1	1	1	
10	5DH-22212-50	.SPRING (K=5.4)	1	1	1	1	1	
11	5DH-22214-00	.GUIDE, SPRING 1	1	1	1	1	1	
12	5DH-22224-00	.GUIDE, SPRING 2	1	1	1	1	1	
13	5DH-22253-00	.COLLAR, DISTANCE	2	2	2	2	2	
14	3JE-22475-00	.SEAL, DUST	4	4	4	4	4	
15	4EW-22253-00	.COLLAR, DISTANCE	2	2	2	2	2	
16	4EW-22474-00	.SEAL, RING	4	4	4	4	4	
17	90105-10323	BOLT, WASHER BASED	1	1	1	1	1	
18	95617-10200	NUT, SELF-LOCKING	1	1	1	1	1	
19	90105-105A2	BOLT, WASHER BASED	1	1	1	1	1	
20	90201-112U6	WASHER, PLATE	1	1	1	1	1	

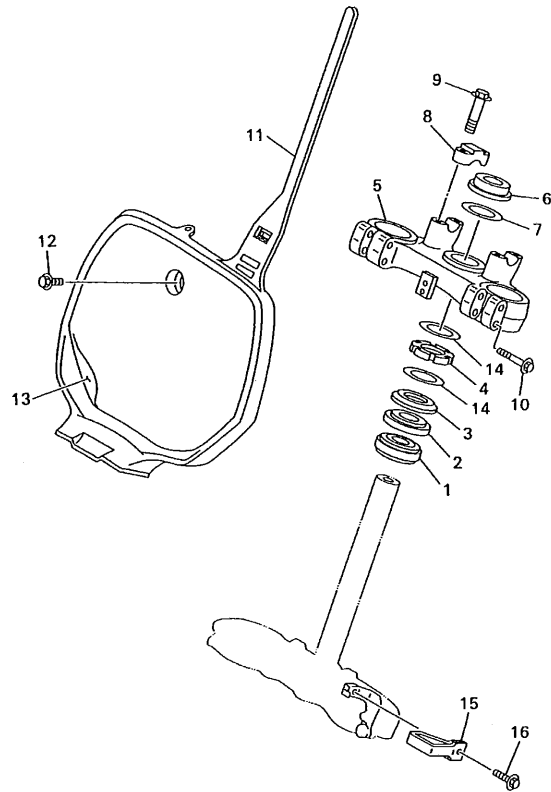

FIG. 24 STEERING

REF. NO.	PART NO.	DESCRIPTION	USA	CAN	OC	EUR	JPN	REMARKS
1	93332-00081	BEARING	1	1	1	1	1	
2	93332-00068	BEARING	1	1	1	1	1	
3	4EW-23416-00	COVER, BALL RACE 2	1	1	1	1	1	
4	90179-28650	NUT	1	1	1	1	1	
5	4SS-23435-00	CROWN, HANDLE	1	1	1	1	1	
6	90170-24373	NUT	1	1	1	1	1	
7	90201-247L2	WASHER, PLATE	1	1	1	1	1	
8	3SP-23441-00	HOLDER, HANDLE UPPER	2	2	2	2	2	
9	95027-08035	BOLT, FLANGE	4	4	4	4	4	
10	95027-08040	BOLT, FLANGE	4	4	4	4	4	
11	4DA-23485-20	PLATE, NUMBER	1	1	1			
	4DA-23485-01	PLATE, NUMBER				1	1	
12	90119-06185	BOLT, WITH WASHER	1	1	1	1	1	
13	5DH-2339E-00	GRAPHIC 1	1	1	1			
14	90201-286K9	WASHER, PLATE	2	2	2	2	2	
15	4DA-23389-00	GUIDE, CABLE	1	1	1	1	1	
16	90105-05361	BOLT, WASHER BASED	1	1	1	1	1	



5BE100-8240

FIG. 25 FRONT FORK

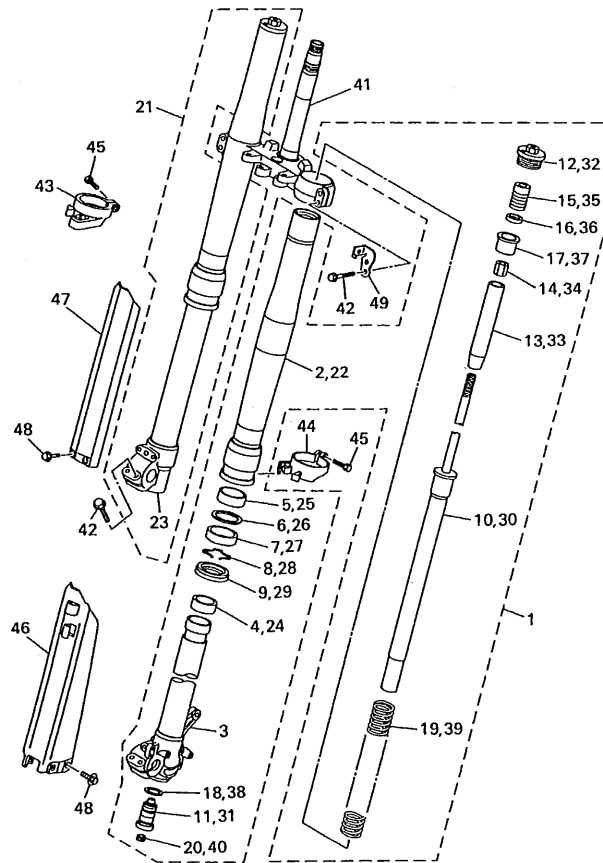

5BE100-8250

REF. NO.	PART NO.	DESCRIPTION	USA	CAN	CE	EUR	JPN	REMARKS
1	5BE-23102-L0	FRONT FORK ASSY (L.H)	1	1	1	1	1	
2	5DH-23136-L0	.TUBE, OUTER (RIGHT)	1	1	1	1	1	
3	5DH-23120-L0	.INNER TUBE COMP.2	1	1	1	1	1	
4	4SS-23171-L0	.PISTON, FRONT FORK	1	1	1	1	1	
5	4SS-23125-L0	.METAL, SLIDE 1	1	1	1	1	1	
6	4SS-23146-L0	.WASHER, OIL SEAL	1	1	1	1	1	
7	5DH-23145-L0	.OIL SEAL	1	1	1	1	1	
8	4SS-23153-L0	.RING, SNAP	1	1	1	1	1	
9	4SS-23144-L0	.SEAL, DUST	1	1	1	1	1	
10	5BE-23170-L0	.CYLINDER COMP., FRONT FORK	1	1	1	1	1	
11	5BE-2316A-L0	.VALVE COMP.	1	1	1	1	1	
12	5DH-23111-L0	.BOLT, CAP	1	1	1	1	1	
13	5DH-23142-L0	.SEAT, SPRING UPPER	1	1	1	1	1	
14	5DH-23393-L0	.NUT, SPECIAL	1	1	1	1	1	
15	5DH-23195-L0	.RUBBER	1	1	1	1	1	
16	5DH-23149-L0	.WASHER, SPRING UPPER	1	1	1	1	1	
17	5DH-23118-L0	.SPACER	1	1	1	1	1	
18	4SS-23158-L0	.GASKET	1	1	1	1	1	
19	5BE-23141-L0	.SPRING, FRONT FORK (K=0.45)	1	1	1	1	1	
20	3JD-2312G-L0	.PLUG	1	1	1	1	1	
21	5BE-23103-L0	FRONT FORK ASSY (R.H)	1	1	1	1	1	
22	5DH-23136-L0	.TUBE, OUTER (RIGHT)	1	1	1	1	1	
23	5BF-23110-L0	.INNER TUBE COMP.1	1	1	1	1	1	
24	4SS-23171-L0	.PISTON, FRONT FORK	1	1	1	1	1	
25	4SS-23125-L0	.METAL, SLIDE 1	1	1	1	1	1	
26	4SS-23146-L0	.WASHER, OIL SEAL	1	1	1	1	1	
27	5DH-23145-L0	.OIL SEAL	1	1	1	1	1	

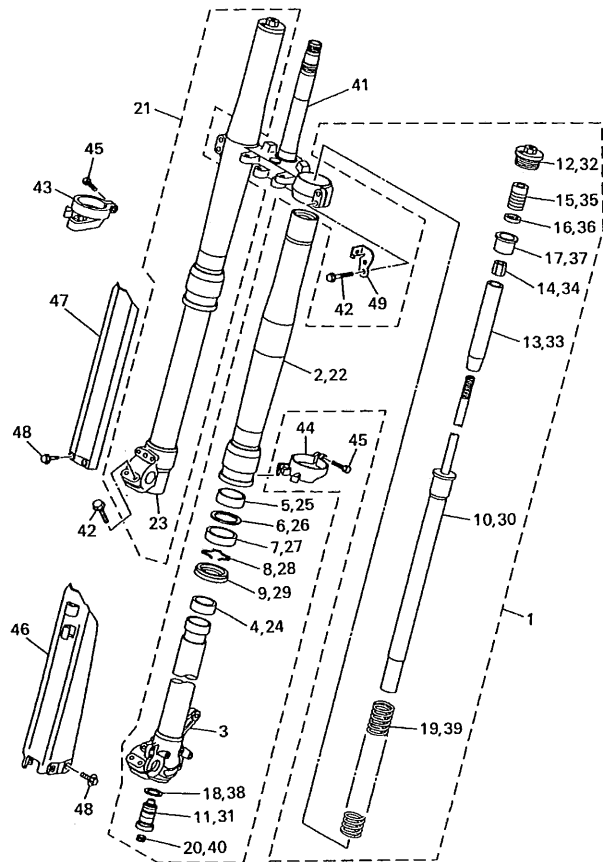

5BE100-8250

FIG. 25 FRONT FORK

REF. NO.	PART NO.	DESCRIPTION	USA	CAN	OCÉ	EUR	JPN	REMARKS
28	4SS-23153-L0	.RING, SNAP	1	1	1	1	1	
29	4SS-23144-L0	.SEAL, DUST	1	1	1	1	1	
30	5BE-23170-L0	.CYLINDER COMP., FRONT FORK	1	1	1	1	1	
31	5BE-2316A-L0	.VALVE COMP.	1	1	1	1	1	
32	5DH-23111-L0	.BOLT, CAP	1	1	1	1	1	
33	5DH-23142-L0	.SEAT, SPRING UPPER	1	1	1	1	1	
34	5DH-23393-L0	.NUT, SPECIAL	1	1	1	1	1	
35	5DH-23195-L0	.RUBBER	1	1	1	1	1	
36	5DH-23149-L0	.WASHER, SPRING UPPER	1	1	1	1	1	
37	5DH-23118-L0	.SPACER	1	1	1	1	1	
38	4SS-23158-L0	.GASKET	1	1	1	1	1	
39	5BE-23141-L0	.SPRING, FRONT FORK (K=0.45)	1	1	1	1	1	
40	3JD-2312G-L0	.PLUG	1	1	1	1	1	
41	5DJ-23340-L0	UNDER BRACKET COMP.	1	1	1	1	1	
42	95021-08040	BOLT, FLANGE	8	8	8	8	8	
43	4SS-2314G-L0	PROTECTOR GUIDE COMP., 2	1	1	1	1	1	
44	5DH-2314F-L0	PROTECTOR GUIDE COMP., 1	1	1	1	1	1	
45	4SS-23346-L0	BOLT 1	2	2	2	2	2	
46	5DH-2314J-00	PROTECTOR COMP., 2	1	1	1	1	1	
47	5DH-2314H-00	PROTECTOR COMP., 1	1	1	1	1	1	
48	3SP-23356-L0	BOLT 2	6	6	6	6	6	
49	4EW-2331E-L0	GUIDE, CABLE	1	1	1	1	1	

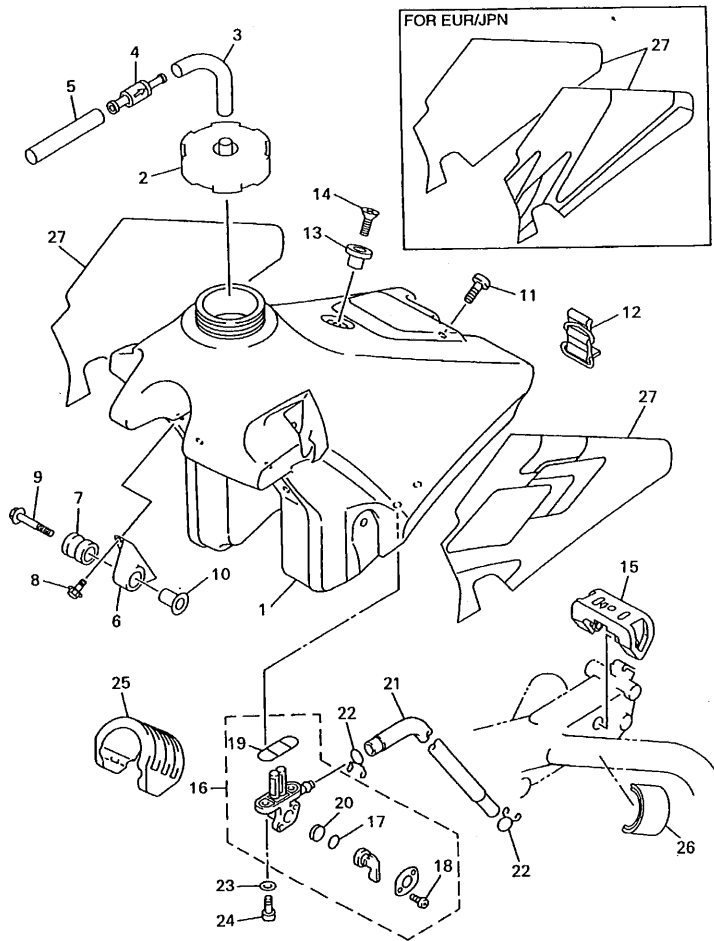

5BE100-8260

FIG. 26 FUEL TANK

REF. NO.	PART NO.	DESCRIPTION	USA	CAN	OCE	EUR	JPN	REMARKS
1	5BE-24110-10	FUEL TANK COMP.	1	1	1			
	5BE-24110-00	FUEL TANK COMP.				1	1	
2	1UY-24610-00	CAP ASSY	1	1	1	1	1	
3	90445-09220	HOSE	1	1	1	1	1	
4	3XJ-24380-00	PIPE JOINT ASSY	1	1	1	1	1	
5	90445-09100	HOSE	1	1	1	1	1	
6	24X-24144-00	HOLDER, DAMPER	2	2	2	2	2	
7	90480-18549	GROMMET	2	2	2	2	2	
8	95027-06016	BOLT, FLANGE	4	4	4	4	4	
9	90119-06214	BOLT, WITH WASHER	2	2	2	2	2	
10	3JD-24186-00	WASHER, SPECIAL	2	2	2	2	2	
11	98907-06020	SCREW, BIND	1	1	1	1	1	
12	3SP-24173-00	BAND, TANK FITTING 1	1	1	1	1	1	
13	4EW-2412F-00	BRACKET, SEAT	1	1	1	1	1	
14	98707-06025	SCREW, FLAT HEAD	1	1	1	1	1	
15	4SS-24181-00	DAMPER, LOCATING 1	1	1	1	1	1	
16	4DP-24500-00	FUEL COCK ASSY 1	1	1	1	1	1	
17	3AJ-24534-00	.SEAL, COCK	1	1	1	1	1	
18	97801-03008	.SCREW, PAN HEAD	2	2	2	2	2	
19	4X8-24512-00	.O-RING	1	1	1	1	1	
20	3AJ-24523-00	.VALVE PACKING	1	1	1	1	1	
21	90445-114K9	HOSE	1	1	1	1	1	
22	90467-10008	CLIP	2	2	2	2	2	
23	90202-05193	WASHER, PLATE	2	2	2	2	2	
24	90149-06011	SCREW	2	2	2	2	2	
25	5BE-24182-00	DAMPER, LOCATING 2	1	1	1	1	1	
26	3V6-22358-00	SEAL 1	2	2	2	2	2	

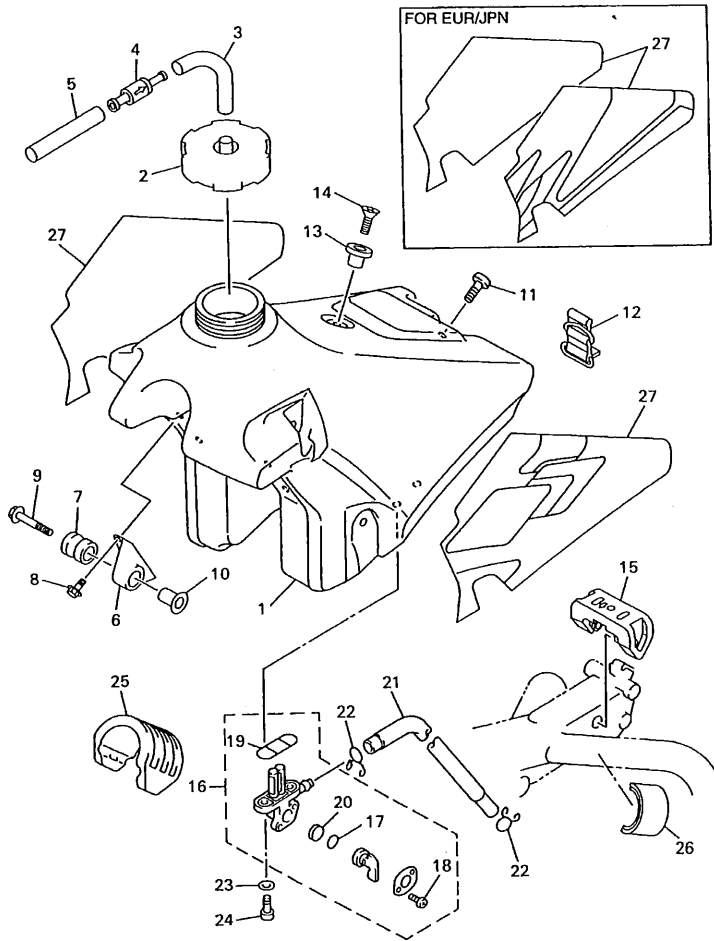

5BE100-8260

FIG. 26 FUEL TANK

REF. NO.	PART NO.	DESCRIPTION	USA	CAN	OC	EUR	JPN	REMARKS
27	5BE-24240-00	GRAPHIC SET	1	1	1			
	5BE-24240-10	GRAPHIC SET				1	1	

FIG. 27 SEAT

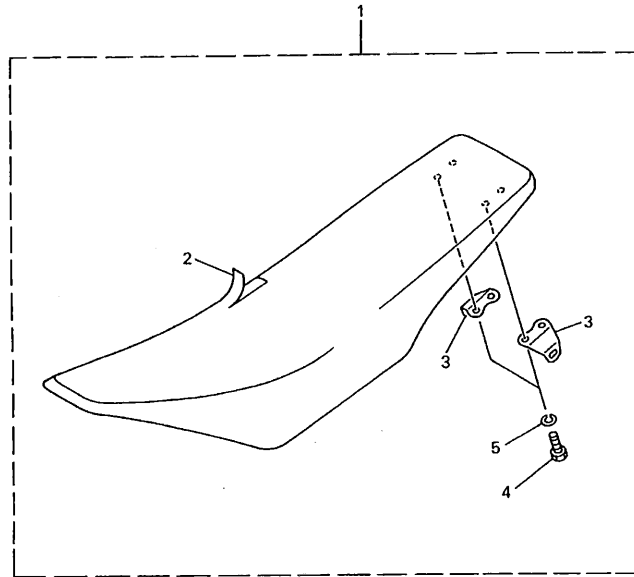

REF. NO.	PART NO.	DESCRIPTION	USA	CAN	OCE	EUR	JPN	REMARKS
1	5BE-24710-10	SINGLE SEAT ASSY	1	1	1			
	5BE-24710-00	SINGLE SEAT ASSY				1	1	
2	5BE-24731-10	.COVER, SEAT	1	1	1			
	5BE-24731-00	.COVER, SEAT				1	1	
3	5BE-24728-00	.BRACKET, SEAT	2	2	2	2	2	
4	97007-06012	.BOLT	4	4	4	4	4	
5	92907-06100	.WASHER, SPRING	4	4	4	4	4	



5BE100-8270

FIG. 28 FRONT WHEEL

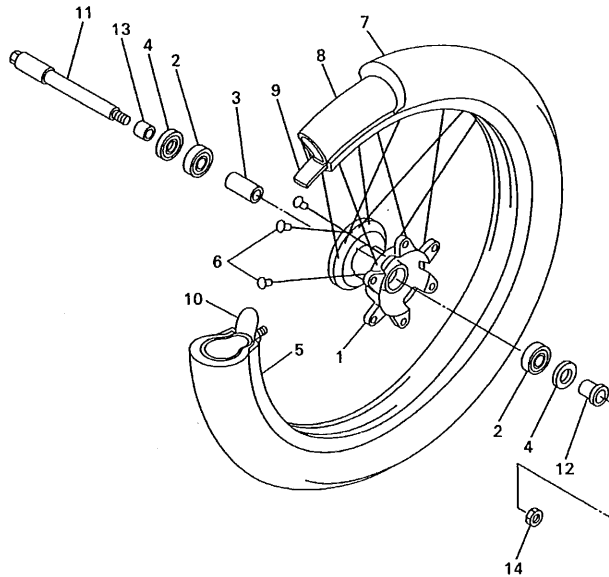

REF. NO.	PART NO.	DESCRIPTION	USA	CAN	OCE	EUR	JPN	REMARKS
1	4SS-25111-00	HUB, FRONT	1	1	1	1	1	
2	93306-90403	BEARING	2	2	2	2	2	
3	5DH-25117-00	SPACER, BEARING	1	1	1	1	1	
4	93102-26468	OIL SEAL	2	2	2	2	2	
5	94416-21509	RIM (1.60-21)	1	1	1	1	1	
6	4DA-25104-00	SPOKE SET, FRONT	1	1	1	1	1	
7	94108-217X2	TIRE (80/100-21 K490)	1		1			DUNLOP
	94108-2110Y	TIRE (80/100-21 51M M77)					1	BRIDGESTONE
	94108-2112Y	TIRE (80/100-21 D755F)		1		1		DUNLOP
8	94227-21101	TUBE (80/100-21 TR4 BTL)	1	1	1	1	1	DUNLOP
	94209-21229	TUBE (80/100C-21 TR4)					1	BRIDGESTONE
9	94307-21145	BAND, RIM (70-80/100-21)	1	1	1	1	1	DUNLOP
	94330-21084	BAND, RIM (3.00-21)					1	BRIDGESTONE
10	2J5-25394-01	SPACER, BEAD	1	1	1	1	1	
11	5BE-25181-00	AXLE, WHEEL	1	1	1	1	1	
12	5DH-25183-00	COLLAR, WHEEL	1	1	1	1	1	
13	5BE-25186-00	COLLAR, WHEEL	1	1	1	1	1	
14	90179-16672	NUT	1	1	1	1	1	



5BE100-8280

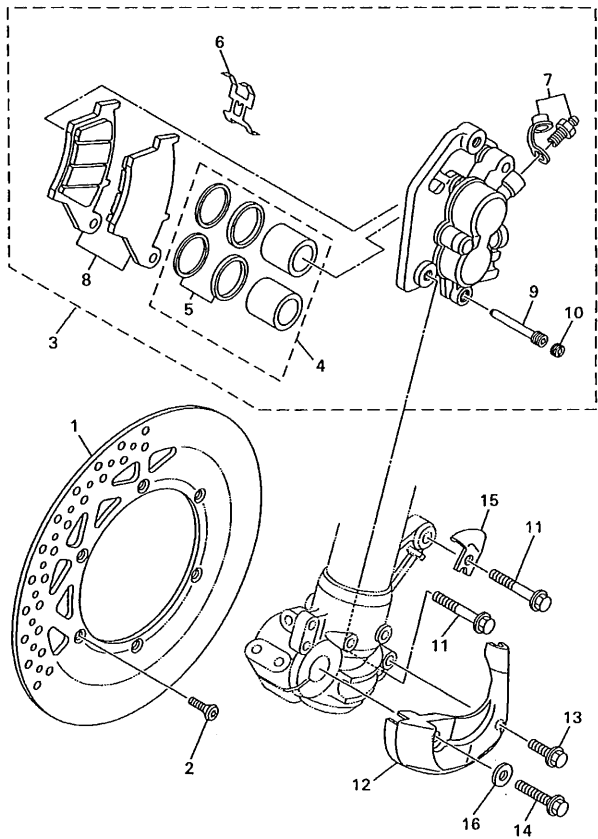

FWD
5BE100-8290

FIG. 29 FRONT BRAKE CALIPER

REF. NO.	PART NO.	DESCRIPTION	USA	CAN	OCE	EUR	JPN	REMARKS
1	4XM-2582T-00	DISC, BRAKE	1	1	1	1	1	
2	90149-06327	SCREW	6	6	6	6	6	
3	5DH-2580T-00	CALIPER ASSY (LEFT)	1	1	1	1	1	
4	4EW-W0057-00	.PISTON ASSY, CALIPER	1	1	1	1	1	
5	3JD-W0047-00	..CALIPER SEAL KIT	1	1	1	1	1	
6	5DH-25919-00	..SUPPORT, PAD	1	1	1	1	1	
7	1UY-W0048-50	..BLEED SCREW KIT	1	1	1	1	1	
8	5DH-W0045-00	..BRAKE PAD KIT	1	1	1	1	1	
9	5DH-25933-00	..PIN, PAD	1	1	1	1	1	
10	5DH-25916-00	..PLUG	1	1	1	1	1	
11	90105-08659	BOLT, WASHER BASED	2	2	2	2	2	
12	5DH-2314E-00	COVER, HOSE	1	1	1	1	1	
13	95827-06012	BOLT, FLANGE	1	1	1	1	1	
14	95027-08020	BOLT, FLANGE	1	1	1	1	1	
15	5DH-25875-00	HOLDER, BRAKE HOSE 1	1	1	1	1	1	
16	92907-08200	WASHER	1	1	1	1	1	

FIG. 30 REAR WHEEL

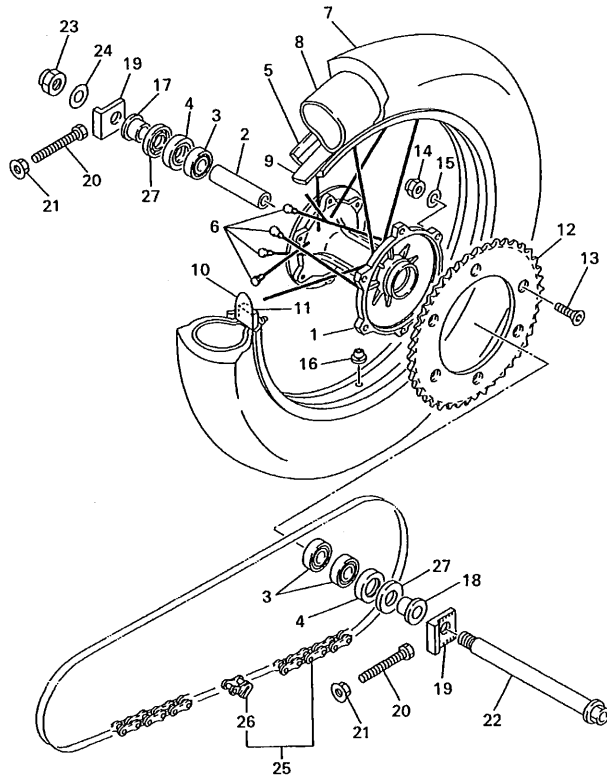

5BE100-8300

REF. NO.	PART NO.	DESCRIPTION	USA	CAN	OC	EUR	JPN	REMARKS
1	4EW-25311-00	HUB, REAR	1	1	1	1	1	
2	4EW-25317-00	SPACER, BEARING	1	1	1	1	1	
3	93306-00418	BEARING	3	3	3	3	3	
4	93106-28023	OIL SEAL	2	2	2	2	2	
5	94421-19538	RIM (2.15-19)	1	1	1	1	1	
6	4XM-25304-00	SPOKE SET, REAR	1	1	1	1	1	
7	94111-1902Y	TIRE (110/90-19 62M K695)	1		1			DUNLOP
	94111-1913A	TIRE (110/90-19 D755)		1		1		DUNLOP
	94111-1911B	TIRE (110/90-19 62M M78A)					1	BRIDGESTONE
8	94211-19273	TUBE (110/90 110/100-19TR4)	1	1	1	1	1	DUNLOP
	94211-19274	TUBE (MCS 110/90-19 TR4)					1	BRIDGESTONE
9	94311-19155	BAND, RIM (110/90 110/100-19)	1	1	1	1	1	DUNLOP
	94321-19157	BAND, RIM (2.15-19)					1	BRIDGESTONE
10	3JE-25394-00	SPACER, BEAD	1	1	1	1	1	
11	4XM-25364-00	DAMPER	1	1	1	1	1	
12	4SS-25449-00	SPROCKET, DRIVEN (49T)	1	1	1	1	1	STD
	4SS-25447-00	SPROCKET, DRIVEN (47T)	1	1	1	1	1	AP
	4SS-25448-00	SPROCKET, DRIVEN (48T)	1	1	1	1	1	AP
	4SS-25450-00	SPROCKET, DRIVEN (50T)	1	1	1	1	1	AP
	4SS-25451-00	SPROCKET, DRIVEN (51T)	1	1	1	1	1	AP
	4SS-25452-00	SPROCKET, DRIVEN (52T)	1	1	1	1	1	AP
13	90109-081G1	BOLT	6	6	6	6	6	
14	95617-08200	NUT, SELF-LOCKING	6	6	6	6	6	
15	90201-08326	WASHER, PLATE	6	6	6	6	6	
16	90480-08608	GROMMET	1	1	1	1	1	
17	90387-2000B	COLLAR	1	1	1	1	1	
18	90387-2000C	COLLAR	1	1	1	1	1	

FIG. 31 REAR BRAKE CALIPER

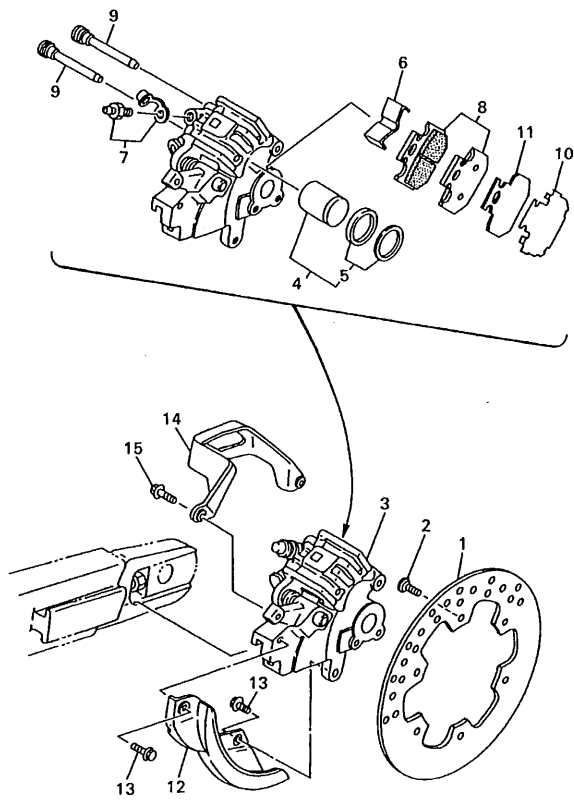

REF. NO.	PART NO.	DESCRIPTION	USA	CAN	OE	EUR	JPN	REMARKS
1	4MX-2582W-00	DISC, REAR BRAKE 2	1	1	1	1	1	
2	90149-06327	SCREW	6	6	6	6	6	
3	4XL-2580W-00	CALIPER ASSY, REAR 2	1	1	1	1	1	
4	3SP-W0057-50	.PISTON ASSY, CALIPER	1	1	1	1	1	
5	3JD-W0047-50	.CALIPER SEAL KIT	1	1	1	1	1	
6	4GY-25919-50	.SUPPORT, PAD	1	1	1	1	1	
7	1UY-W0048-50	.BLEED SCREW KIT	1	1	1	1	1	
8	4GY-W0046-00	.BRAKE PAD KIT 2	1	1	1	1	1	
9	3SP-25924-51	.PIN, PAD	2	2	2	2	2	
10	4XM-25827-50	.SHIM, CALIPER	1	1	1	1	1	
11	4GY-22898-50	.INSULATOR, HEAT	1	1	1	1	1	
12	4MX-25718-00	PROTECTOR, DISK BRAKE	1	1	1	1	1	
13	95027-06012	BOLT, FLANGE	2	2	2	2	2	
14	4GY-27491-00	PROTECTOR	1	1	1	1	1	
15	95027-06016	BOLT, FLANGE	2	2	2	2	2	



5BE100-8310

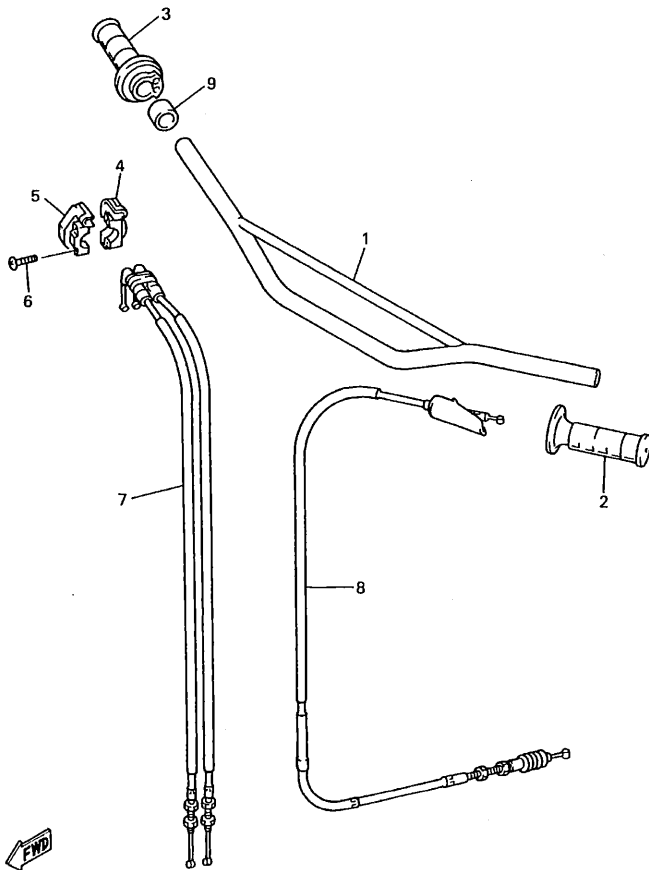

5BE100-8320

FIG. 32 STEERING HANDLE. CABLE

REF. NO.	PART NO.	DESCRIPTION	USA	CAN	OC	EUR	JPN	REMARKS
1	4XM-26111-00	HANDLEBAR	1	1	1	1	1	
2	4GY-26241-00	GRIP (LEFT)	1	1	1	1	1	
3	5BE-26240-00	GRIP ASSY	1	1	1	1	1	
4	5BE-26281-00	CAP, GRIP UPPER	1	1	1	1	1	
5	5BE-26282-00	CAP, GRIP LOWER	1	1	1	1	1	
6	98507-05020	SCREW, PAN HEAD	2	2	2	2	2	
7	5BE-26302-00	THROTTLE CABLE ASSY	1	1	1	1	1	
8	5BE-26335-00	CABLE, CLUTCH	1	1	1	1	1	
9	90387-225N2	COLLAR	1	1	1	1	1	

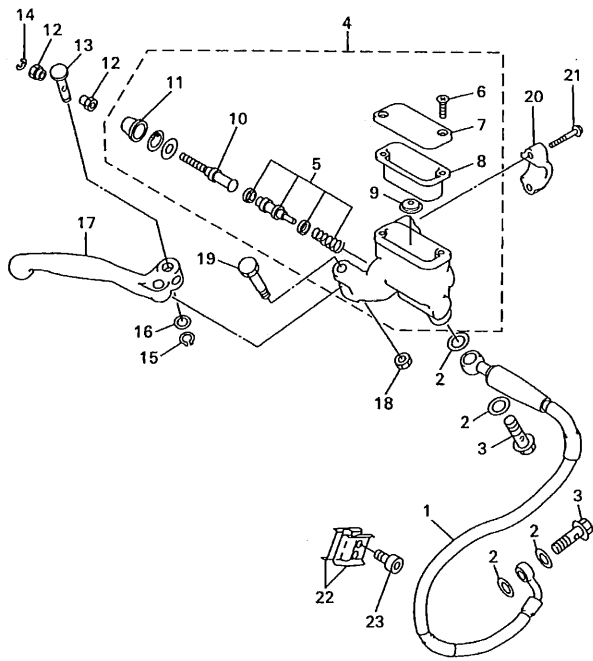

FIG. 33 FRONT MASTER CYLINDER

REF. NO.	PART NO.	DESCRIPTION	USA	CAN	OE	EUR	JPN	REMARKS
1	5DH-25872-00	HOSE, BRAKE 1	1	1	1	1	1	
2	90201-10118	WASHER, PLATE	4	4	4	4	4	
3	90401-10172	BOLT, UNION	2	2	2	2	2	
4	4SS-W2587-00	MASTER CYLINDER SUB ASSY	1	1	1	1	1	
5	4SS-W0041-00	.CYLINDER KIT, MASTER	1	1	1	1	1	
6	98706-04012	.SCREW, FLAT HEAD	2	2	2	2	2	
7	4SS-25852-00	.CAP, RESERVOIR	1	1	1	1	1	
8	4SS-25854-00	.DIAPHRAGM, RESERVOIR	1	1	1	1	1	
9	4SS-25889-00	.SEPARATOR ASSY	1	1	1	1	1	
10	4SS-25880-00	.PUSH ROD COMP.	1	1	1	1	1	
11	4SS-25868-00	.BOOT, MASTER CYLINDER	1	1	1	1	1	
12	4SS-2538E-00	NUT, ADJUSTING	2	2	2	2	2	
13	4SS-83913-00	COLLAR, LEVER 1	1	1	1	1	1	
14	3YX-25866-10	CIRCLIP	1	1	1	1	1	
15	4SS-25866-00	CIRCLIP	1	1	1	1	1	
16	4SS-2583G-00	WASHER	1	1	1	1	1	
17	4SS-83922-01	LEVER 2	1	1	1	1	1	
18	95606-06100	NUT, U	1	1	1	1	1	
19	4SS-2589F-00	BOLT, LEVER	1	1	1	1	1	
20	3YK-25867-00	BRACKET, MASTER CYLINDER	1	1	1	1	1	
21	4SS-25833-00	BOLT, FITTING	2	2	2	2	2	
22	90465-16258	CLAMP	2	2	2	2	2	
23	91317-06014	BOLT	2	2	2	2	2	



5BE100-8330

FIG. 34 STAND, FOOTREST

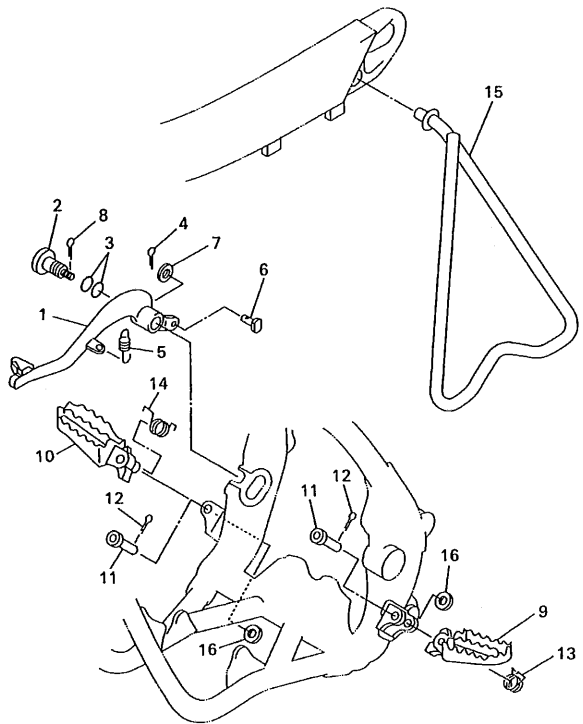

REF. NO.	PART NO.	DESCRIPTION	USA	CAN	OCE	EUR	JPN	REMARKS
1	4XM-27200-00	PEDAL, BRAKE	1	1	1	1	1	
2	4SS-27217-00	BOLT	1	1	1	1	1	
3	93210-11073	O-RING	2	2	2	2	2	
4	91401-20012	PIN, COTTER	1	1	1	1	1	
5	90506-16500	SPRING, TENSION	1	1	1	1	1	
6	90240-08120	PIN, CLEVIS	1	1	1	1	1	
7	90201-08089	WASHER, PLATE	1	1	1	1	1	
8	90468-16191	CLIP	1	1	1	1	1	
9	4XM-27411-00	FOOTREST 1	1	1	1	1	1	
10	4XM-27421-00	FOOTREST 2	1	1	1	1	1	
11	90240-10142	PIN, CLEVIS	2	2	2	2	2	
12	91401-25015	PIN, COTTER	2	2	2	2	2	
13	90508-282B8	SPRING, TORSION	1	1	1	1	1	
14	90508-282B9	SPRING, TORSION	1	1	1	1	1	
15	3SP-27311-00	STAND, SIDE	1	1	1	1	1	
16	90201-10119	WASHER, PLATE	2	2	2	2	2	



5BE100-8340

FIG. 35 REAR MASTER CYLINDER

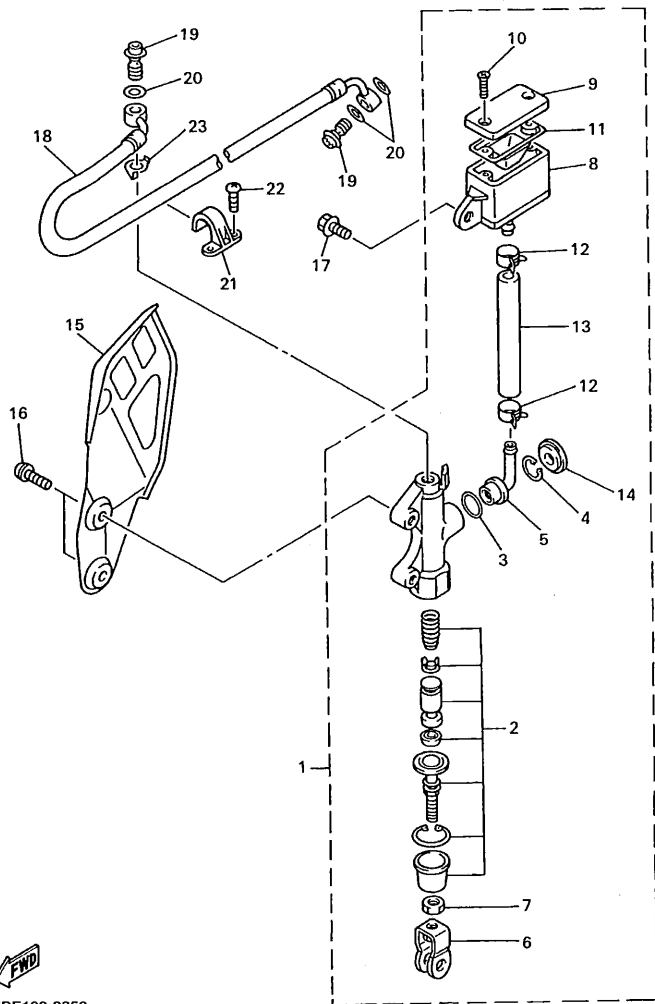

REF. NO.	PART NO.	DESCRIPTION	USA	CAN	OCÉ	EUR	JPN	REMARKS
1	5BE-2583V-00	RR. MASTER CYLINDER ASSY.	1	1	1	1	1	
2	5BE-W0042-00	.CYLINDER KIT, MASTER	1	1	1	1	1	
3	93210-15620	.O-RING	1	1	1	1	1	
4	2VN-25866-00	.CIRCLIP	1	1	1	1	1	
5	4ML-2582A-50	.JOINT	1	1	1	1	1	
6	3SP-27222-00	.JOINT	1	1	1	1	1	
7	95301-08700	.NUT	2	2	2	2	2	
8	5BE-25894-00	.TANK, RESERVOIR	1	1	1	1	1	
9	5BE-25852-00	.CAP, RESERVOIR	1	1	1	1	1	
10	98706-04040	.SCREW, FLAT HEAD	2	2	2	2	2	
11	56A-25854-00	.DIAPHRAGM, RESERVOIR	1	1	1	1	1	
12	90467-12085	.CLIP	2	2	2	2	2	
13	5BE-25895-00	.HOSE, RESERVOIR	1	1	1	1	1	
14	3FV-2589A-00	.COVER, DUST	1	1	1	1	1	
15	5BE-2117M-00	COVER 2	1	1	1	1	1	
16	92014-06016	BOLT, BUTTON HEAD	2	2	2	2	2	
17	95027-06012	BOLT, FLANGE	1	1	1	1	1	
18	4SS-25873-01	HOSE, BRAKE 2	1	1	1	1	1	
19	90401-10172	BOLT, UNION	2	2	2	2	2	
20	90201-10118	WASHER, PLATE	3	3	3	3	3	
21	2VM-25876-00	HOLDER, BRAKE HOSE 2	2	2	2	2	2	
22	97780-50510	SCREW, TAPPING	4	4	4	4	4	
23	5BE-25844-00	WASHER, LOCK	1	1	1	1	1	

FWD
5BE100-8350

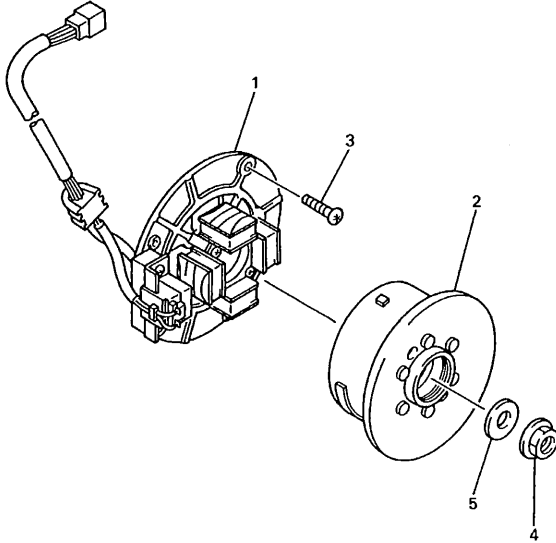

FIG. 36 GENERATOR

REF. NO.	PART NO.	DESCRIPTION	USA	CAN	OCE	EUR	JPN	REMARKS
1	5BE-85560-00	BASE ASSY	1	1	1	1	1	
2	5BE-85550-00	ROTOR ASSY	1	1	1	1	1	
3	90149-06324	SCREW	3	3	3	3	3	
4	90179-10394	NUT	1	1	1	1	1	
5	90201-10591	WASHER, PLATE	1	1	1	1	1	



5BE100-8360

FIG. 37 HANDLE SWITCH, LEVER

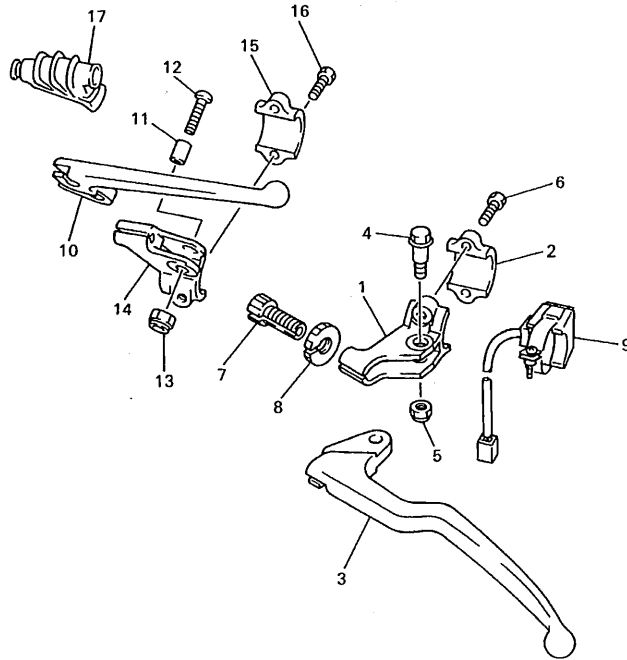

REF. NO.	PART NO.	DESCRIPTION	USA	CAN	OC	EUR	JPN	REMARKS
1	38V-82911-00	HOLDER, LEVER 1	1	1	1	1	1	
2	38V-82913-00	HOLDER, LEVER LOWER 1	1	1	1	1	1	
3	4GY-83912-00	LEVER 1	1	1	1	1	1	
4	90109-06799	BOLT	1	1	1	1	1	
5	95607-06100	NUT, U	1	1	1	1	1	
6	97007-05016	BOLT	2	2	2	2	2	
7	90123-08090	BOLT	1	1	1	1	1	
8	90179-08401	NUT	1	1	1	1	1	
9	23X-83976-00	SWITCH, HANDLE 1	1	1	1	1	1	
10	583-83981-00	LEVER, DECOMPRESSION	1	1	1	1	1	
11	5BE-83913-00	COLLAR, LEVER 1	1	1	1	1	1	
12	98907-05020	SCREW, BIND	1	1	1	1	1	
13	95607-05100	NUT, U	1	1	1	1	1	
14	5BE-82912-00	HOLDER, LEVER UPPER 1	1	1	1	1	1	
15	38V-82913-00	HOLDER, LEVER LOWER 1	1	1	1	1	1	
16	97007-05016	BOLT	2	2	2	2	2	
17	583-26352-00	COVER, CABLE	1	1	1	1	1	



5BE100-8370

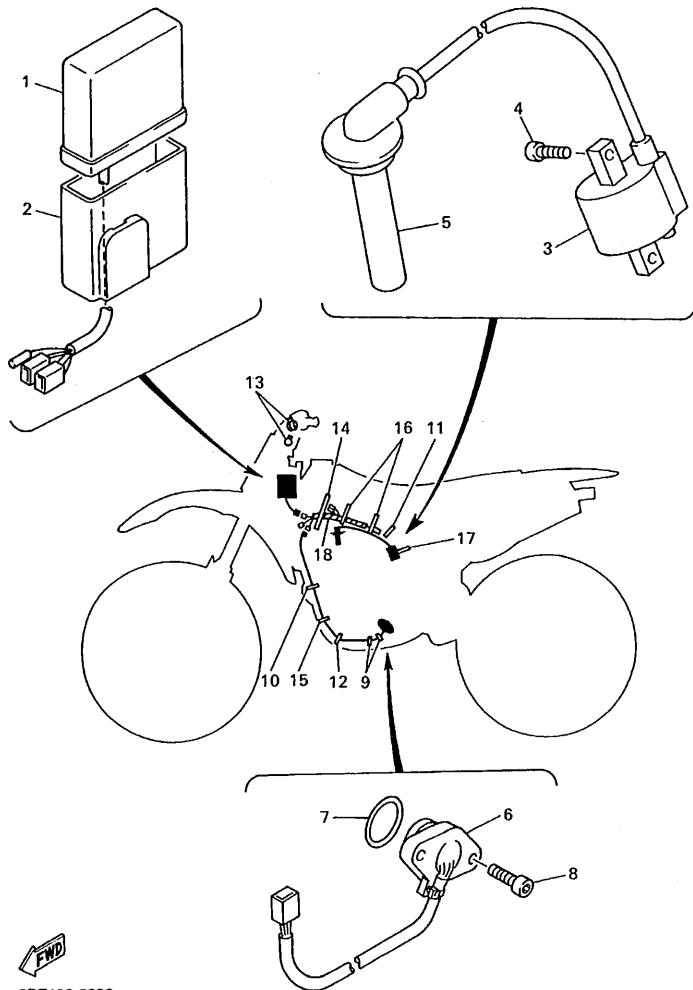

5BE100-8380

FIG. 38 ELECTRICAL 1

REF. NO.	PART NO.	DESCRIPTION	USA	CAN	OCÉ	EUR	JPN	REMARKS
1	5BE-85540-00	C.D.I. UNIT ASSY	1	1	1	1	1	
2	5BE-85546-00	BAND	1	1	1	1	1	
3	5BE-82310-00	IGNITION COIL ASSY	1	1	1	1	1	
4	91317-06016	BOLT	2	2	2	2	2	
5	5BE-82370-00	PLUG CAP ASSY	1	1	1	1	1	
6	5BE-82540-00	NEUTRAL SWITCH ASSY	1	1	1	1	1	
7	93210-21276	O-RING	1	1	1	1	1	
8	90154-05073	SCREW, BINDING	2	2	2	2	2	
9	90464-16061	CLAMP	2	2	2	2	2	
10	90464-13073	CLAMP	1	1	1	1	1	
11	90464-15195	CLAMP	1	1	1	1	1	
12	90460-15126	CLAMP, HOSE	1	1	1	1	1	
13	90464-13077	CLAMP	2	2	2	2	2	
14	90464-15152	CLAMP	1	1	1	1	1	
15	90464-13073	CLAMP	1	1	1	1	1	
16	90465-13275	CLAMP	2	2	2	2	2	
17	90464-15195	CLAMP	1	1	1	1	1	
18	5BE-82509-00	WIRE, SUB LEAD	1	1	1	1	1	

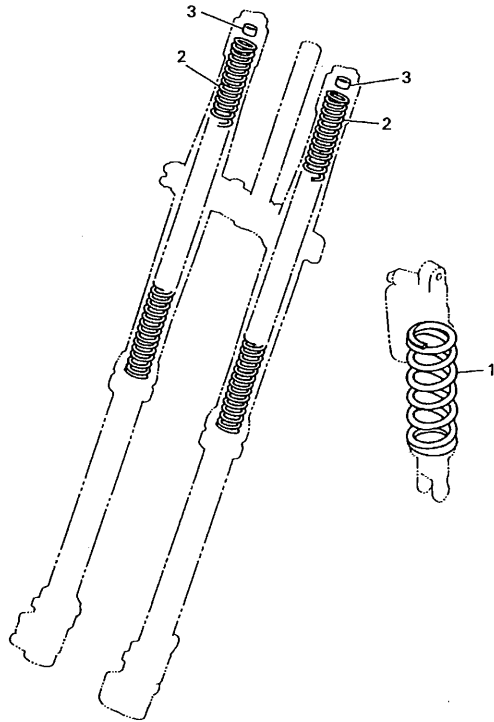

FIG. 39 ALTERNATE (CHASSIS)

REF. NO.	PART NO.	DESCRIPTION	USA	CAN	OCÉ	EUR	JPN	REMARKS
1	5DH-22212-10	SPRING (K=4.6)	1	1	1	1	1	AP
	5DH-22212-20	SPRING (K=4.8)	1	1	1	1	1	AP
	5DH-22212-30	SPRING (K=5.0)	1	1	1	1	1	AP
	5DH-22212-40	SPRING (K=5.2)	1	1	1	1	1	AP
	5DH-22212-50	SPRING (K=5.4)	1	1	1	1	1	AP
	5DH-22212-60	SPRING (K=5.6)	1	1	1	1	1	AP
2	4SS-23141-10	SPRING, FRONT FORK (K=0.38)	2	2	2	2	2	AP
	4SS-23141-20	SPRING, FRONT FORK (K=0.39)	2	2	2	2	2	AP
	4SS-23141-30	SPRING, FRONT FORK (K=0.40)	2	2	2	2	2	AP
	4SS-23141-40	SPRING, FRONT FORK (K=0.41)	2	2	2	2	2	AP
	4SS-23141-50	SPRING, FRONT FORK (K=0.42)	2	2	2	2	2	AP
	4SS-23141-60	SPRING, FRONT FORK (K=0.43)	2	2	2	2	2	AP
	4SS-23141-70	SPRING, FRONT FORK (K=0.44)	2	2	2	2	2	AP
	5BE-23141-00	SPRING, FRONT FORK (K=0.46)	2	2	2	2	2	AP
3	4SS-23364-L0	COLLAR 2	1	1	1	1	1	UN



5BE100-8390

NUMERICAL INDEX

PARTNO.	GRID NO.	PARTNO.	GRID NO.	PARTNO.	GRID NO.	PARTNO.	GRID NO.	PARTNO.	GRID NO.	PARTNO.	GRID NO.
4SS-W0041-00	E - 6	3FV-12153-10	B - 6	5BE-12577-00	B - 9	5BE-14417-00	B - 14	5BE-14916-EO	C - 2	5BE-14985-00	C - 3
5BE-W0042-00	E - 8	3FV-12153-20	B - 6	5BE-12578-00	B - 9	5BE-1443E-00	B - 13	5BE-14916-EP	C - 2	5BE-14987-00	C - 5
5DH-W0045-00	D - 15	3LD-12168-A0	B - 5	5BE-12579-00	B - 9	5BE-14449-00	C - 4	5BE-14916-EQ	C - 2	4FN-14997-00	B - 15
4GY-W0046-00	E - 4	3LD-12168-FO	B - 5	583-13113-00	C - 8	4XM-14451-00	B - 13	5BE-14916-ER	C - 2	5BE-15150-00	C - 7
3JD-W0047-00	D - 15	3LD-12168-H1	B - 5	5BE-13161-00	B - 12	5BE-14453-00	B - 13	5BE-14916-ES	C - 2	5BE-15362-00	D - 2
3JD-W0047-50	E - 4	3LD-12168-K1	B - 5	5BE-13171-00	B - 12	5BE-14458-00	B - 13	5BE-14916-ET	C - 2	4JT-15381-01	C - 7
1UY-W0048-50	D - 15	3LD-12168-M1	B - 5	5BE-13300-00	B - 10	3JD-14459-01	B - 13	5BE-14916-EU	C - 2	5BE-15383-00	C - 7
	E - 4	3LD-12168-R1	B - 5	1HX-13310-00	B - 10	3JD-14477-00	B - 13	5BE-14922-00	C - 4	5BE-15411-00	C - 8
	E - 4	3LD-12168-U1	B - 5	5BE-13341-00	B - 10	3TJ-14496-40	B - 15	3TJ-14933-40	C - 3	5BE-15415-00	C - 8
3SP-W0057-50	D - 15	3LD-12168-W1	B - 5	5BE-13342-00	B - 10	3JD-14521-00	C - 2	4FN-14934-00	C - 4	5BE-15421-00	C - 7
4EW-W0057-00	E - 6	3LD-12168-Y1	B - 5	5BE-13411-00	B - 10	3TJ-14522-40	B - 15	5BE-14937-00	C - 5	5BE-15431-00	C - 8
4SS-W2587-00	E - 6	3LD-12168-00	B - 5	5BE-13412-00	B - 10	5BE-14534-00	C - 4	3TJ-1494F-09	C - 3	5BE-15441-00	C - 7
5BE-11102-00	B - 2	3LD-12168-20	B - 5	5BE-13416-00	B - 10	5BE-14535-00	C - 4	3TJ-1494F-10	C - 3	5BE-15451-00	C - 8
4KG-1111G-00	B - 3	3LD-12168-40	B - 5	1UY-13440-02	B - 12	3TJ-14536-40	C - 3	3TJ-1494F-11	C - 3	5BE-15453-00	C - 8
5BE-11133-10	B - 2	3LD-12168-60	B - 5	5BE-13447-00	B - 12	4FN-14546-00	B - 15	3TJ-1494F-12	C - 3	5BE-15462-00	C - 8
5BE-11134-10	B - 2	3LD-12168-80	B - 5	5BE-13464-00	B - 10	676-14548-00	C - 3	3TJ-1494F-13	C - 3	5BE-15601-00	C - 9
5BE-11166-00	B - 3	3LD-12169-E0	B - 6	5BE-13465-00	B - 10	5BE-14557-00	C - 4	3TJ-1494F-14	C - 3	5BE-15620-00	C - 9
371-11167-01	B - 3	3LD-12169-G0	B - 6	5BE-13582-00	B - 2	4FN-14561-00	B - 13	3TJ-1494F-15	C - 3	5BE-15651-00	C - 9
5BE-11167-00	B - 2	3LD-12169-J0	B - 6	5BE-13597-00	B - 13	5BE-14561-00	C - 4	3TJ-1494F-16	C - 3	5BE-15664-00	C - 9
5BE-11181-00	B - 2	3LD-12169-L0	B - 6	5BE-14101-00	B - 15	6H4-14561-00	C - 3	3TJ-1494F-17	C - 3	5BE-15668-00	C - 9
5BE-11191-00	B - 2	3LD-12169-N0	B - 6	3TJ-14105-40	C - 3	5BE-14562-00	C - 4	5BE-14940-05	C - 3	5BE-15674-00	C - 9
5BE-11193-00	B - 3	3LD-12169-T0	B - 6	5BE-14107-00	C - 3	688-14592-00	C - 3	5BE-14940-07	C - 3	5BE-15686-00	C - 9
5BE-11311-00	B - 3	3LD-12169-11	B - 5	5BE-14115-00	C - 4	5BE-14596-00	C - 4	5BE-14940-08	C - 3	5BE-16111-00	C - 10
5BE-11351-00	B - 3	3LD-12169-31	B - 6	3TJ-14137-40	C - 4	5BE-14611-00	C - 6	5BE-14940-09	C - 3	5BE-16150-00	C - 10
5BE-11400-00	B - 4	3LD-12169-50	B - 6	5BE-14137-00	C - 4	3VD-14613-00	C - 6	3TJ-14943-47	C - 2	2JN-16154-00	C - 10
5BE-11412-00	B - 4	3LD-12169-70	B - 6	5BE-14146-00	C - 4	5BE-14628-00	C - 6	5BE-14943-40	C - 2	5BE-16321-00	C - 10
5BE-11422-00	B - 4	3LD-12169-90	B - 6	5BE-14148-00	C - 4	5BE-1469A-00	C - 6	4MX-14943-41	C - 2	360-16325-00	C - 10
5BE-11454-00	B - 4	5BE-12170-00	B - 7	3TJ-14159-40	C - 2	5BE-1469A-10	C - 6	4MX-14943-42	C - 2	5BE-16331-00	C - 10
5BE-11455-00	B - 4	5BE-12180-00	B - 7	5BE-14162-00	C - 4	3GW-14714-00	C - 6	4MX-14943-43	C - 2	3YF-16351-00	C - 10
5BE-11531-00	B - 4	5BE-12210-00	B - 7	5BE-14171-00	C - 4	5BE-14747-00	C - 6	4MX-14943-44	C - 2	5BE-16356-00	C - 10
5BE-11536-00	B - 4	4FM-12213-00	B - 7	5BE-14197-00	C - 4	5BE-14753-00	C - 6	4MX-14943-45	C - 2	5BE-16357-00	C - 10
5BE-11603-00	B - 4	5BE-12241-00	B - 7	5BE-14216-00	C - 3	5BE-14753-10	C - 6	4MX-14943-91	C - 2	2JN-16371-00	C - 10
5BE-11631-01-A0	B - 4	5BE-12251-00	B - 7	5BE-14265-00	C - 4	4BD-14766-00	C - 6	4MX-14943-92	C - 2	5BE-16381-00	C - 10
5BE-11631-01-B0	B - 4	5BE-12252-00	B - 7	3TJ-14267-40	B - 15	5BE-14788-00	C - 6	4MX-14943-93	C - 2	4JT-16384-00	C - 10
5BE-11633-00	B - 4	5BE-12280-00	B - 7	3TJ-14293-40	C - 3	5BE-14916-CO	B - 15	4MX-14943-94	C - 2	5BE-17121-00	C - 11
5BE-11651-00	B - 4	5BE-12283-00	B - 7	5BE-14293-00	B - 13	5BE-14916-CP	B - 15	4MX-14943-95	C - 2	5BE-17131-00	C - 11
5BE-11681-00	B - 4	5BE-12292-00	B - 7	5BE-14326-00	C - 4	5BE-14916-CQ	B - 15	7A9-14943-27	C - 3	5BE-17141-00	C - 11
5BE-12111-00	B - 5	5BE-1240A-00	B - 9	5BE-14340-00	B - 13	5BE-14916-CR	B - 15	5BE-14947-00	C - 2	5BE-17151-00	C - 11
5BE-12112-00	B - 5	5BE-12422-00	B - 8	5BE-14346-00	C - 5	5BE-14916-CS	B - 15	3TJ-14948-02	C - 2	5BE-17211-00	C - 11
5BE-12113-00	B - 5	5BE-12439-00	B - 8	5BE-14349-00	B - 14	5BE-14916-CT	B - 15	3TJ-14948-03	C - 2	5BE-17221-00	C - 11
5BE-12114-00	B - 5	5DJ-12451-00	B - 8	3TJ-14365-40	C - 4	5BE-14916-CU	B - 15	3TJ-14948-04	C - 2	5BE-17231-00	C - 11
4GY-12117-00	B - 5	5BE-12458-00	B - 8	5BE-14379-00	C - 4	5BE-14916-DO	B - 15	3TJ-14948-05	C - 2	5BE-17241-00	C - 11
5BE-12117-00	B - 5	5BE-12461-00	B - 9	5BE-14386-00	B - 15	5BE-14916-DP	B - 15	3TJ-14948-06	C - 2	5BE-17251-00	C - 11
5BE-12118-00	B - 5	22W-12462-00	B - 9	3TJ-14393-40	B - 15	5BE-14916-DQ	B - 15	3TJ-14948-07	C - 3	5BE-17411-00	C - 11
1AA-12118-00	B - 5	5BE-12481-00	B - 9	5BE-1440F-00	B - 13	5BE-14916-DR	B - 15	3TJ-14948-08	C - 3	5BE-17421-00	C - 11
1WG-12118-00	B - 5	5BE-12482-00	B - 9	5BE-14401-00	B - 13	5BE-14916-DS	B - 15	5BE-14959-00	B - 15	5BE-17466-00	C - 7
33M-12119-00	B - 5	5BE-12564-00	B - 8	5BE-1441A-00	B - 13	5BE-14916-DT	B - 15	5BE-14968-00	C - 4	4LO-17471-00	C - 7
4SV-12119-00	B - 5	5BE-12576-00	B - 9	5BE-1441E-00	B - 13	5BE-14916-DU	B - 15	3TJ-14984-40	C - 3	5BE-17471-00	C - 12
5BE-12121-00	B - 5										
3GM-12126-00	B - 5										

NUMERICAL INDEX

PARTNO.	GRID NO.	PARTNO.	GRID NO.	PARTNO.	GRID NO.	PARTNO.	GRID NO.	PARTNO.	GRID NO.	PARTNO.	GRID NO.
3XK-18101-02	C-14	156-22127-00	D-5	5DH-23136-L0	D-9	3SP-23441-00	D-8	5DH-2580T-00	D-15	4GY-27491-00	E-4
5BE-18110-00	C-14	4XM-22128-00	D-5	5DH-2314E-00	D-15	4DA-23485-01	D-8	4XL-2580W-00	E-4	56A-28166-00	D-2
3XK-18122-00	C-14	5DH-22129-00	D-5	5DH-2314F-L0	D-10	4DA-23485-20	D-8	4ML-2582A-50	E-8	5BE-82310-00	E-11
3XK-18140-00	C-13	5DH-22141-00	D-5	4SS-2314G-L0	D-10	5BE-24110-00	D-11	4XM-2582T-00	D-15	5BE-82370-00	E-11
5BE-18172-00	C-14	4EW-22151-20	D-5	5DH-2314H-00	D-10	5BE-24110-10	D-11	4MX-2582W-00	E-4	5BE-82509-00	E-11
3XJ-18173-00	C-14	5DH-2217A-00	D-5	5DH-2314J-00	D-10	4EW-2412F-00	D-11	4XM-25827-50	E-4	5BE-82540-00	E-11
3XJ-18178-00	C-14	5DH-2217F-00	D-6	4SS-23141-10	E-12	24X-24144-00	D-11	4SS-2583G-00	E-6	38V-82911-00	E-10
3XJ-18182-00	C-14	3JD-22178-10	C-15	4SS-23141-20	E-12	3SP-24173-00	D-11	5BE-2583V-00	E-8	5BE-82912-00	E-10
3XJ-18184-00	C-14	4EW-22178-00	C-15	4SS-23141-30	E-12	22W-24181-00	C-6	4SS-25833-00	E-6	38V-82913-00	E-10
4EW-18185-00	C-14	4XM-22199-00	D-5	4SS-23141-40	E-12	4SS-24181-00	D-11	5BE-25844-00	E-8	4GY-83912-00	E-10
5BE-18501-00	C-13	5BE-22201-00	D-7	4SS-23141-50	E-12	5BE-24182-00	D-11	4SS-25852-00	E-6	4SS-83913-00	E-6
5BE-18502-00	C-13	5BE-22201-10	D-7	4SS-23141-60	E-12	3JD-24186-00	D-11	5BE-25852-00	E-8	5BE-83913-00	E-10
5BE-18503-00	C-13	5BE-22201-20	D-7	4SS-23141-70	E-12	5BE-24240-00	D-12	4SS-25854-00	E-6	4SS-83922-01	E-6
5BE-18541-00	C-13	5BE-22201-30	D-7	5BE-23141-L0	D-9	5BE-24240-10	D-12	56A-25854-00	E-8	23X-83976-00	E-10
4BA-18542-00	C-13	5BE-22210-00	D-7			3XJ-24380-00	D-11	2VN-25866-00	E-8	583-83981-00	E-10
5DH-18562-00	C-7	5BE-22210-10	D-7	5BE-23141-00	E-12	4DP-24500-00	D-11	3YX-25866-10	E-6	5BE-85540-00	E-11
5BE-21101-00-P0	C-15	5BE-22210-20	D-7	5DH-23142-L0	D-9	4X8-24512-00	D-11	4SS-25866-00	E-6	4SS-85546-00	E-11
5BE-21101-00-7B	C-15	5BE-22210-30	D-7			3AJ-24523-00	D-11	3YK-25867-00	E-6	5BE-85550-00	E-9
5BE-2117M-00	E-8	5DH-22212-10	E-12	4SS-23144-L0	D-9	3AJ-24534-00	D-11	4SS-25868-00	E-6	5BE-85560-00	E-9
5BE-21190-00-P0	C-15	5DH-22212-20	E-12			1UY-24610-00	D-11	5DH-25872-00	E-6	5BE-85885-00	C-4
5BE-21190-00-7B	C-15	5DH-22212-30	E-12	5DH-23145-L0	D-9	5BE-24710-00	D-13	4SS-25873-01	E-8	90101-06664	C-14
1HX-2135F-10	D-6	5DH-22212-40	E-12	4SS-23146-L0	D-9	5BE-24710-10	D-13	5DH-25875-00	D-15	90101-08777	E-3
5BE-21417-00	C-15	5DH-22212-50	D-7	5DH-23149-L0	D-9	5BE-24728-00	D-13	2VM-25876-00	E-8	90105-05361	D-8
5BE-21425-00	C-15		E-12			5BE-24731-00	D-13	4SS-25880-00	E-6	90105-06153	B-2
5BE-2147A-00	D-2	5DH-22212-60	E-12	4SS-23153-L0	D-9	5BE-24731-10	D-13	4SS-25889-00	E-6	90105-065A1	C-8
5BE-21471-00	D-2	3SP-22213-00	D-7			4DA-25104-00	D-14	3FV-2589A-00	E-8	90105-06553	C-7
4DA-21511-00	D-3	5DH-22214-00	D-7	4SS-23158-L0	D-9	4SS-25111-00	D-14	4SS-2589F-00	E-6		C-12
4DA-21511-20	D-3	5DH-22224-00	D-7			5DH-25117-00	D-14	5BE-25894-00	E-8	90105-08099	C-15
3FY-21575-01	D-4	4JX-22226-00	D-7	5BE-2316A-L0	D-9	5BE-25181-00	D-14	5BE-25895-00	E-8	90105-08659	D-15
5BE-21611-00	D-3	3SP-22234-00	D-7			5DH-25183-00	D-14	5DH-25916-00	D-15	90105-08752	C-9
5BE-21611-10	D-3	4EW-22253-00	D-7	5BE-23170-L0	D-9	5BE-25186-00	D-14	4GY-25919-50	E-4	90105-10323	D-7
5BE-2163G-00	D-3	5DH-22253-00	D-7			4XM-25304-00	E-2	5DH-25919-00	D-15	90105-104A7	B-2
5BE-2163G-10	D-3	4SS-22355-00	D-5	4SS-23171-L0	D-9	4EW-25311-00	E-2	3SP-25924-51	E-4	90105-105A2	D-7
5BE-21642-00	D-3	3V6-22358-00	D-11	5DH-23183-00	D-7	4EW-25317-00	E-2	5DH-25933-00	D-15	90105-106A3	B-2
5BE-21711-00	D-4	4EW-22474-00	D-7	509-23184-L0	D-7	4XM-25364-00	E-2	4XM-26111-00	E-5	90105-10733	C-15
4EW-2172A-10	D-4	3JE-22475-00	D-7	5DH-23195-L0	D-9	4V4-25367-00	E-3	5BE-26240-00	E-5	90109-063F8	C-13
5BE-21721-00	D-4	4GY-22898-50	E-4			4SS-2538E-00	E-6	4GY-26241-00	E-5	90109-06418	B-7
5BE-2173E-01	D-4	5BE-23102-L0	D-9	4EW-2331E-L0	D-10	3JD-25381-01	E-3	5BE-26281-00	E-5	90109-065G2	B-12
5BE-2173E-11	D-4	5BE-23103-L0	D-9	5DJ-23340-L0	D-10	3SP-25388-00	E-3	5BE-26282-00	E-5	90109-066F0	B-2
5BE-2173F-01	D-4	5BF-23110-L0	D-9	4SS-23346-L0	D-10	2J5-25394-01	D-14	5BE-26302-00	E-5	90109-06799	E-10
5BE-2173F-11	D-4	5DH-23111-L0	D-9	3SP-23356-L0	D-10	3JE-25394-00	E-2	5BE-26335-00	E-5	90109-081G1	E-2
5BE-21731-00	D-4		D-10	4SS-23364-L0	E-12	4SS-25447-00	E-2	583-26352-00	E-10	90109-142F4	D-6
5BE-21731-10	D-4	5DH-23118-L0	D-9	4DA-23389-00	D-8	4SS-25448-00	E-2	4XM-27200-00	E-7	90109-147F2	D-5
5BE-2174A-00	D-4		D-10	5DH-2339E-L0	D-8	4SS-25449-00	E-2	4SS-27217-00	E-7	90110-05201	D-5
5BE-21741-00	D-4	3JD-2312G-L0	D-9	4SS-25450-00	D-9	4SS-25450-00	E-2	3SP-27222-00	E-8	90110-08096	C-15
5BE-21741-10	D-4		D-10	4SS-25451-00	D-10	4SS-25451-00	E-2	3SP-27311-00	E-7	90111-06017	B-13
3JD-21748-00	D-3	5DH-23120-L0	D-9	4EW-23416-00	D-8	4SS-25452-00	E-2	4XM-27411-00	E-7	90119-06096	D-3
5BE-22210-00	D-5	4SS-23125-L0	D-9	4SS-23435-00	D-8	4MX-25718-00	E-4	4XM-27421-00	E-7	90119-06185	D-8

NUMERICAL INDEX

PARTNO.	GRID NO.	PARTNO.	GRID NO.	PARTNO.	GRID NO.	PARTNO.	GRID NO.	PARTNO.	GRID NO.	PARTNO.	GRID NO.
90119-06214	D - 11	90201-10591	E - 9	90387-2000B	E - 2	90501-16107	C - 9	93210-07003	B - 12	93608-33046	C - 14
90119-08238	D - 4	90201-112U6	D - 7	90387-2000C	E - 2	90501-244L9	C - 10	93210-07135	B - 12	93612-16254	B - 3
90122-06035	B - 13	90201-12166	B - 10	90387-2113G	C - 11	90506-16500	E - 7	93210-09008	B - 12	9383E-14210	C - 12
90123-08090	E - 10	90201-125L6	C - 10	90387-225N2	E - 5	90508-142B5	C - 10	93210-10197	B - 10	94108-2110Y	D - 14
90149-06011	D - 11	90201-14740	D - 6	90387-2513F	C - 11	90508-162B2	B - 7		C - 7	94108-2112Y	D - 14
90149-06250	B - 4	90201-15701	C - 8	90401-08038	B - 12	90508-26561	C - 13	93210-11073	E - 7	94108-217X2	D - 14
90149-06286	C - 7	90201-162H4	C - 9	90401-10159	B - 12	90508-282B8	E - 7	93210-12759	B - 12	94111-1902Y	E - 2
90149-06324	E - 9	90201-164H4	D - 5	90401-10172	E - 6	90508-282B9	E - 7	93210-14369	C - 8	94111-1911B	E - 2
90149-06326	C - 7		D - 6		E - 8	90508-291A8	C - 14	93210-15620	E - 8	94111-1913A	E - 2
90149-06327	D - 15	90201-167P7	C - 9	90430-06014	C - 9	90508-30743	C - 9	93210-18397	B - 9	94209-21229	D - 14
	E - 4	90201-20276	C - 9	90430-06166	B - 8	91A20-05065	B - 9	93210-19123	D - 2	94211-19273	E - 2
90151-04048	D - 5	90201-20685	C - 9	90430-08119	B - 12	91314-06030	B - 10	93210-19758	B - 8	94211-19274	E - 2
90154-05073	E - 11	90201-247L2	D - 8	90430-10188	B - 12	91316-04008	B - 15	93210-21276	E - 11	94227-21101	D - 14
90159-06078	D - 4	90201-253K0	C - 11	90430-12213	C - 7	91316-04012	B - 15	93210-22298	C - 11	94307-21145	D - 14
90159-06092	C - 10	90201-286K9	D - 8	90445-09100	D - 11	91317-05014	B - 13	93210-32172	C - 8	94311-19155	E - 2
90159-06182	D - 4	90202-03052	C - 4	90445-09220	D - 11	91317-05050	C - 4	93210-50553	B - 12	94321-19157	E - 2
90170-14171	B - 4	90202-05193	D - 11	90445-112K0	B - 3	91317-06014	E - 6	93300-60804	C - 15	94330-21084	D - 14
90170-20327	C - 10	90202-08045	B - 15	90445-114K9	D - 11	91317-06016	E - 11	93306-00105	B - 8	94416-21509	D - 14
90170-24373	D - 8	90206-06090	C - 6	90450-22017	B - 10	91317-06025	B - 10	93306-00418	E - 2	94421-19538	E - 2
90179-06500	B - 3	90209-06096	B - 13	90450-25037	B - 9	91317-06040	C - 7	93306-00426	C - 11	94581-68114	E - 3
90179-06568	D - 5	90209-21332	C - 11	90450-28014	B - 9	91317-06050	C - 7	93306-00431	C - 11	94591-50120	B - 7
90179-08270	B - 3	90209-26348	C - 11	90450-57092	B - 13	91317-06060	C - 7	93306-20335	B - 4	94681-68001	E - 3
90179-08401	E - 10	90215-14204	B - 4	90450-59091	B - 13	91317-06075	C - 7	93306-20532	C - 11	94701-00318	B - 2
90179-10394	E - 9	90215-20231	C - 10	90460-15126	E - 11	91317-08020	C - 6	93306-20593	C - 11	94701-00319	B - 2
90179-16672	D - 14	90215-21256	C - 12	90460-61162	B - 13	91401-20012	E - 7	93306-30633	B - 4	94701-00329	B - 2
90179-20255	C - 10	90215-21290	C - 10	90461-10136	C - 7	91401-25015	E - 7	93306-90403	D - 14	94701-00330	B - 2
	C - 12	90240-08120	E - 7	90462-10241	C - 8	91808-16023	B - 2	93306-90501	C - 13	94703-00318	B - 2
90179-28650	D - 8	90240-10142	E - 7	90464-13073	E - 11	91812-16001	C - 8	93310-6340F	B - 4	94703-00319	B - 2
90183-06023	B - 13	90267-32070	B - 13	90464-13077	E - 11	92014-06016	E - 8	93311-62574	B - 4	94703-00329	B - 2
	D - 3	90280-03045	B - 4	90464-15152	E - 11	92017-08055	C - 15	93315-11206	C - 10	94703-00330	B - 2
90183-06069	D - 4	90282-05034	B - 4	90464-15195	E - 11	92907-06100	D - 13	93315-32056	D - 5	95021-06040	D - 10
90185-14112	D - 6	90338-16148	C - 15	90464-16061	E - 11	92907-06600	B - 7		D - 6	95024-06020	B - 11
90185-16127	D - 5		D - 5	90465-13275	E - 11	92907-08200	D - 15	93317-22262	D - 5	95027-06010	C - 10
90185-18104	E - 3	90340-12059	C - 7	90465-16258	E - 6	92907-10200	C - 15	93332-00068	D - 8		D - 5
90201-03313	B - 13	90340-12112	B - 2	90467-09006	B - 9	92907-18600	E - 3	93332-00081	D - 8	95027-06012	B - 9
90201-06071	B - 9	90340-14128	C - 8	90467-09103	B - 14	93101-14164	C - 8	93340-21505	C - 10		B - 12
90201-06557	D - 3	90340-32123	C - 8	90467-10008	D - 11	93102-12106	B - 8	93342-22215	D - 5		B - 13
90201-08089	E - 7	90387-0600F	D - 3	90467-11106	B - 3		C - 14	93410-20038	C - 9		D - 3
90201-081R9	C - 6	90387-0614M	B - 9	90467-12085	E - 8	93102-12224	B - 7	93420-18082	B - 4		E - 4
90201-08326	E - 2	90387-0701A	D - 3	90467-14015	B - 3		C - 10	93440-10085	B - 10		E - 8
90201-08410	C - 4	90387-0814J	C - 6	90467-17089	B - 13	93102-20108	C - 9		C - 10	95027-06014	D - 3
90201-08512	B - 8	90387-086N4	C - 15	90468-16191	E - 7	93102-26468	D - 14	93440-10153	B - 2	95027-06016	B - 14
90201-086P8	C - 15	90387-124F4	C - 14	90480-08608	E - 2	93102-32480	C - 11	93440-25084	C - 11		D - 11
90201-087A9	C - 9	90387-164N2	D - 5	90480-15528	B - 9	93106-22019	D - 5	93440-28062	C - 11		E - 4
90201-10144	B - 2	90387-164N3	D - 5	90480-18549	D - 11	93106-28023	E - 2	93440-41178	B - 7	95027-06020	B - 12
90201-10118	E - 6	90387-167Y9	D - 5	90501-043E0	C - 8	93109-11073	B - 8	93503-08007	C - 8		C - 14
	E - 8	90387-1712R	D - 5	90501-052G5	C - 14	93109-20076	D - 5	93603-17070	B - 10	95027-06025	B - 7
90201-10119	E - 7	90387-1712Y	C - 7	90501-06022	C - 13		D - 6	93604-10011	B - 8		B - 8

NUMERICAL INDEX

PARTNO.	GRID NO.	PARTNO.	GRID NO.	PARTNO.	GRID NO.	PARTNO.	GRID NO.	PARTNO.	GRID NO.
95027-06025	B - 9	98706-04040	E - 8						
	B - 10	98707-06025	D - 11						
	B - 11	98907-05020	E - 10						
95027-06030	C - 8	98907-06020	D - 11						
95027-06040	B - 3	98980-06008	C - 6						
	C - 8	99001-08600	B - 10						
95027-06050	D - 5	99009-12400	B - 10						
95027-06065	B - 12	99009-16400	C - 9						
95027-08012	D - 2	99009-20400	C - 9						
95027-08020	D - 15	99009-22500	C - 8						
95027-08035	D - 8	99241-00080	D - 3						
95027-08040	C - 15	99244-00080	D - 3						
	D - 8	99244-00200	D - 6						
95027-08065	C - 15	99530-08012	B - 10						
95027-10055	C - 15	99530-08016	C - 8						
95301-08700	E - 8	99530-10114	B - 10						
95606-06100	E - 6		C - 7						
95607-05100	B - 13	99530-10116	C - 7						
	E - 10	99530-14016	C - 7						
95607-06100	E - 10								
95607-08200	C - 15								
95617-06635	B - 2								
95617-08200	E - 2								
95617-08620	B - 2								
95617-08635	B - 2								
95617-10200	C - 15								
	D - 7								
95704-05500	C - 4								
95707-08500	B - 2								
	C - 15								
	E - 3								
95817-10160	C - 15								
95827-06012	D - 15								
95827-06014	B - 7								
95827-06016	D - 4								
95827-08012	C - 6								
95827-08016	D - 2								
95827-08030	C - 6								
97007-05016	E - 10								
97007-06012	D - 13								
97027-06016	B - 7								
	C - 9								
97707-60016	D - 3								
97780-50510	E - 8								
97801-03008	D - 11								
98507-05020	E - 5								
98507-06025	C - 7								
98706-04012	E - 6								